

**Amateur Radio
at the South Pole**

FEBRUARY 1980 / \$1.25

HAM RADIO HORIZONS

**HOW TO PLAN YOUR
TOWER INSTALLATION**

**CLOSET HAMSHACK —
A CONDOMINIUM SPECIAL**

**A LAZY ANTENNA FOR 160 —
BIG IN PERFORMANCE,
SMALL IN SIZE**

**LOW-COST POWER SUPPLIES —
YOUR BUCK BUYS A BARGAIN**

PLUS:

- Using Your Multi Meter
- Sharing Amateur Radio
- New Sources for Ham Gear



THE OMNI SYSTEM — tools of the trade for serious DX operators, contesters, traffic, nets, or just rag chewing — designed to give you the operating edge.

Simply Super. The keynote of a Ten-Tec OMNI is simplicity of operation combined with super performance. No tricky controls, no distracting readings, no fussy adjustments. Your operating is pure enjoyment, unhampered by complexity, enhanced by features that are meaningful, advanced by options that are realistic.

Instant Band Change—to catch the openings. Just flip the bandswitch, no tuning the transmitter. A convenience originated by Ten-Tec in modern transceivers.

Full Break-In—for CW with perfect timing, for a real conversation in code. And slow break-in at the flip of a switch to suit band conditions or quiet mobile operation.

Ultra Selectivity—to fit any band condition. Standard 2.4 kHz 8-pole crystal ladder filter for normal reception; optional 1.8 kHz filter (\$55) operates in series with the 2.4 kHz filter to transform an unreadable signal in heavy QRM into one that gets the message through; optional 0.5 kHz 8-pole filter (\$55) provides steep, deep skirts to the CW passband window to cut out even those strong adjacent signals; standard 150 Hz CW active audio filters have three ranges (450, 300, 150 Hz) for further attenuation of adjacent signals and band noise.

Variable Notch Filter—to eliminate interfering carriers and CW signals. Attenuation is more than 8 "S" units (over 50 dB).

Six-Function Separate VFO—for complete versatility in working DX. Independent transmit and receive frequencies with OMNI; reversible at the touch of a button for full monitoring of the action. Even allows simultaneous reception on both VFO and OMNI with transmission on either. LEDs show status. An optional operating bargain at \$139.

Speech Processor and Microphone—to extend your operating range under adverse conditions by increasing average envelope power without derating the OMNI power limits and with minimum distortion. Model 234 is a true RF processor, model 214 is a peak-free condenser microphone. An optional system for optimum speech energy, 234 is \$124, 214 is \$39.

Electronic Keyer—key to perfect CW. Styled to match OMNI; self-completing; dit and dah memories with individual defeat switches; automatic variable weighting; adjustable magnetic paddle return; and more for just \$85.

Matching Power Supply—to completely power the OMNI system. Regulated, over-current protected, switched from OMNI or front panel, and only \$139.

Plus All These Famous Standard Features of OMNI—All Solid-State, 160-10 Meters, Built-in VOX and PTT, Dual-Range Receiver Offset Tuning, Wide Overload Capabilities, Adjustable Sidetone Tone and Level, Exceptional Sensitivity, 200 Watts Input, Adjustable ALC, 100% Duty Cycle, Phone Patch Interface Jacks, Zero-Beat Switch, "S"/SWR Meter, Dual Speakers, Plug-In Circuit Boards, Complete Shielding, Rigid Light-Weight Aluminum Construction, Comfortable Operating Size (5¾" h x 14¼" w x 14" d).

Model 545 Series B OMNI-A (analog transceiver) \$ 949

Model 546 Series B OMNI-D (digital transceiver) \$1119

Get The Operating Edge — Get The OMNI System. See your Ten-Tec dealer or write for full details.



TEN-TEC, HF equipment supplier to
Winter Olympics Radio Amateur Network (WORAN)

THE OPERATING EDGE



Swan's Success Story:

100MX Power House

The Field-Proven Rig the Whole World's Talking About.

235 Watt PEP
and CW on
ALL Bands

Price? You won't
believe it! Just ask
your dealer.

All solid state quality American
construction, with epoxy glass
boards to withstand the
rugged mobile environment.



Look to Swan for Quality Accessories . . . and Service



SWAN
ELECTRONICS

A member of the Cubic Corporation family of companies.

305 Airport Road
Oceanside, CA 92054
714-757-7525

THIS MONTH'S

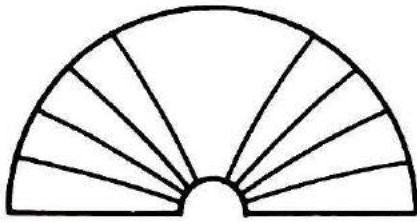

HORIZONS

Amateur Radio in Antarctica

Snow — miles and miles of it. Sometimes it invades your shack, buries your equipment, or lets your building sink into its depths. As if that were not enough, there are the months of isolation — with family and friends half a globe away. Amateur Radio operators provide “phone patches” that are vital to the mental well-being of scientific and military personnel at Antarctic bases — stations that seem almost as remote as the moon. Veteran phone-patcher W8HXR gives you some inkling of life in the frozen south, starting on page 12.

Sharing Amateur Radio

You're enjoying one of the greatest hobbies on earth, so how about sharing it with some eager and open minds. You don't have to be the world's greatest speaker, or a fantastic engineer; just show some youngsters how you do your own thing with Amateur Radio. N9YL tried ham radio on some youngsters at a nearby school, using a few photographs, some simple gear, and a sample of Morse code — and they loved it. You'll feel good about it too, so read about it on page 18.

Put Your Multimeter To Work

You know about the normal uses of a multimeter — checking

such things as volts, milliamperes, ohms, continuity — right? Well, there's no need to push this most versatile of test instruments to the back of the shelf. WB2IBE points out several things you can do, both in and out of your shack, to get maximum mileage out of this inexpensive analyzer. The ideas start on page 31.

Low-Cost Power Supplies

The computer age has left a trail of cast-off components, many of them power supplies of uncertain makeup and odd voltages. A little careful purchasing, a bit of work, and some workbench engineering will often turn these leftovers into energy sources for your ICs, transistors, op-amps, lamps, relays, and small motors. Author W6GXN tells you how to make sure your buck buys a bargain.

A Lazy Antenna For 160

One-sixty is a long-time favorite band for many Amateurs. However, antenna requirements are a problem for hams on small lots. Many schemes have been tried, including shunt-fed towers, horizontal wires of uncertain direction and varying height, and loaded whips. K8MN found an easy way out, and calls the resulting antenna a lazy vertical. The name could come from the fact that the antenna leans, or it could be because not much work is required to put it together. Look for the instructions on page 38.

Tower Installation Made Easy

Why make a big production out of installing a tower? Well, WB2LKO produces TV commercials, so it comes natural to him to select and direct the star and supporting cast. Also, if you think of the project as a production to be staged, rather than a chore to be done (digging holes, etc.), it'll go much faster. That

applause you hear is actually better signals from DX land.

Closet Hamshack

Condominium living is the answer to the homeowner's problems — at least according to the advertisements you see and hear. Well, maybe so, unless you're a ham with ambitions toward working DX, chasing WAS, DXCC, and other certificates of merit. Here's WD6GKF's solution to the problem of “where to put the hamshack.” It's a neat station, and works well, but be sure to heed his words of advice before you grab your hammer and nails.

Ham Gear Sources

The CB explosion has spawned thousands of accessories and gadgets, many of which can find useful application in your own hamshack. Since many of these products are inexpensive and easily available, it's worthwhile to consider them. W8FX makes some specific and valuable suggestions for their use.

The Cover

Our artist captures a bird's-eye view of an intrepid DXer getting antennas ready for another season of band openings and contests. Original watercolor by Chris Walker.

HAM RADIO HORIZONS February 1980, Volume 4, Number 2. Published monthly by Communications Technology, Inc., Greenville, New Hampshire 03048. Telephone (603) 878-1441. Second Class Postage paid at Greenville, New Hampshire and at additional mailing offices. ISSN 0147-8818.

Subscription price: Domestic, one year, \$12.00; two years, \$20.00; three years, \$27.00. Canada and Worldwide, one year, \$12.00; two years, \$22.00; three years, \$30.00, payable in United States funds.

Subscription inquiries and changes of address should be directed to *Ham Radio Horizons*, Greenville, New Hampshire 03048. Please include address label from most recent issue if possible.

NEW MFJ-410 "Professor Morse" lets you . . .

COPY CW FASTER AND UPGRADE QUICKER

NEW MFJ Random Code Generator/Keyer sends unlimited random code in random groups for practice. Never repeats same sequence. Tailor level to your ability. Vary speed 5 to 50 WPM. Vary spacing between characters. Speed Meter. Full Feature Keyer.

*Sends unlimited random code.
Never repeats same sequence.
Tailor level to your ability.
Vary speed 5-50 WPM.*



\$149⁹⁵

Copy code faster and upgrade quicker. Now you can tailor the level of code practice to your exact needs. Practice copying code anywhere and anytime you have a spare moment. Practice at home, in bed, driving to work, during lunch, etc.

The new MFJ-410 "Professor Morse" is a computer-like random code generator and keyer that sends an unlimited supply of precision Morse Code in random groups.

It never repeats the same sequence so you can't memorize it like code tapes.

Vary speed 5-50 WPM and read on speed meter.

Vary spacing between characters and character groups (for example, copy 5 WPM with 13 WPM characters) to give proper character sound at low speed.

Select alphabetic only or alphanumeric plus punc-

tuation (period, comma, question, slash, double dash.)

Tone control. Room filling volume. Built-in speaker. Ideal for classroom teaching. Earphone jack (2.5 mm) for private listening.

Uses 110 VAC, or 9-18 VDC, or 4-C cells (for portable use). Optional cable for car cigarette lighter (\$3.00). 6x2x6 inches.

Built-in full feature keyer. Volume, speed, internal tone and weight controls. Weight control adjusts dot-dash space ratio; makes your signal distinctive to penetrate QRM. Speed meter works for keyer, too. Tune switch keys transmitter for tuning. Reliable solid-state keying: grid block, cathode, solid state rigs. **OPTIONAL BENCHER IAMBIC PADDLE.**

Dot and dash paddles have fully adjustable ten-

sion and spacing. Heavy base with non-slip rubber feet eliminates "walking". \$39.95.

Order from MFJ and try it — no obligation. If not delighted, return it within 30 days for refund (less shipping). One year unconditional guarantee.

Order today. Call toll free 800-647-1800. Charge VISA, MC or mail check, money order for \$149.95 plus \$3.00 shipping for MFJ-410 and/or \$39.95 plus \$3.00 shipping for Bencher paddle.

CALL TOLL FREE . . . 800-647-1800

Call 601-323-5869 for technical information, order/repair status. Also call 601-323-5869 outside continental USA and in Mississippi.

MFJ ENTERPRISES, INC.
BOX 494, MISSISSIPPI STATE, MS 39762

NEW MFJ DELUXE Versa Tuner II

\$119.95 buys you one of the world's finest 300 watt antenna tuners with features that only MFJ offers, like . . . dummy load, SWR, forward, reflected power meter, antenna switch, balun. Matches everything from 1.8 thru 30 MHz: coax, random wires, balanced lines.

*MFJ's Best Versa Tuner II . . .
Solid American Quality*

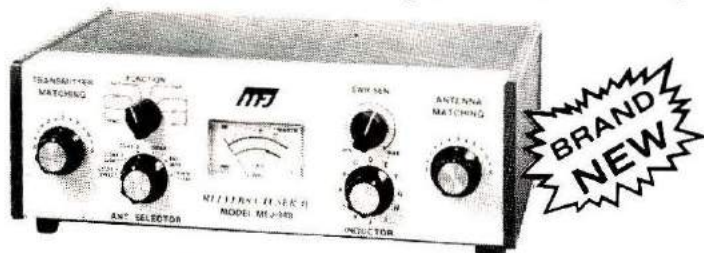

\$119⁹⁵

This is MFJ's best Versa Tuner II. And one of the world's finest 300 watt (RF output) tuners.

The MFJ-949 Deluxe Versa Tuner II gives you a combination of quality, performance, and features that others can't touch at this price . . . or any price.

PERFORMANCE: You can run your full transceiver power output — up to 300 watts RF output — and match your transmitter to any feedline from 1.8 thru 30 MHz whether you have coax, balanced line or random wire.

FEATURES: A 200 watt 50 ohm dummy load lets you tune up for maximum performance.

A sensitive meter lets you read SWR with only 5 watts and both forward and reflected power in two ranges (300 and 30 watts).

A flexible antenna switch lets you select 2 coax lines direct or thru tuner, random wire or balanced line and dummy load.

A large efficient airwound inductor 3 inches in diameter gives you plenty of matching range and less losses for more watts out.

1:4 balun. 1000 volt capacitors. SO-239 coax connectors. Binding post for balanced line, random wire, ground. 10x3x7 inches.

QUALITY: Every single unit is tested for performance and inspected for quality. Solid American construction, quality components.

The MFJ-949 carries a full one year unconditional guarantee.

Order from MFJ and try it — no obligation. If not delighted, return it within 30 days for a re-

fund (less shipping).

To order, simply call us toll free 800-647-1800 and charge it on your VISA or Master Charge or mail us a check or money order for \$119.95 plus \$3.00 for shipping/handling.

Don't wait any longer to tune out that SWR and enjoy solid QSO's. Order your Deluxe Versa Tuner II at no obligation, today.

MFJ ENTERPRISES, INC.
P. O. BOX 494

MISSISSIPPI STATE, MS 39762

CALL TOLL FREE . . . 800-647-1800

For technical information, order/repair status, in Miss., outside continental USA, call 601-323-5869.

New, Stronger Wilson Towers



Hinged Base Plate - Concrete Pad, Heavy Duty Winch



Mounting the House Bracket



The Hinged Base Plate allows tower to be tilted over for access to antenna and rotor from the ground.

FACTORY DIRECT
\$279⁹⁵

TT-45B

FEATURES:

- Maximum Height 45' (will handle 17 sq. ft. @ 38 ft. or 10 sq. ft. @ 45 ft.) @ 50 mph
- 1200 lb. winch
- Totally freestanding with proper base
- Total Weight, 243 lbs.

The TT-45B is a freestanding tower, ideal for installations where guys cannot be used. If the tower is not being supported against the house, the proper base fixture accessory must be selected. (Requires 12"x12"x36" of concrete.)

GENERAL FEATURES

All towers use high strength heavy galvanized steel tubing that conforms to ASTM specifications for years of maintenance-free service. The large diameters provide unexcelled strength. All welding is performed with state-of-the-art equipment. Top sections are 2" O.D. for proper antenna/rotor mounting. A 10' push-up mast is included in the top section of each tower. Hinge-over base plates are standard with each tower. The high loads of today's antennas make Wilson crank-ups a logical choice.

Prices and specifications subject to change without notice.

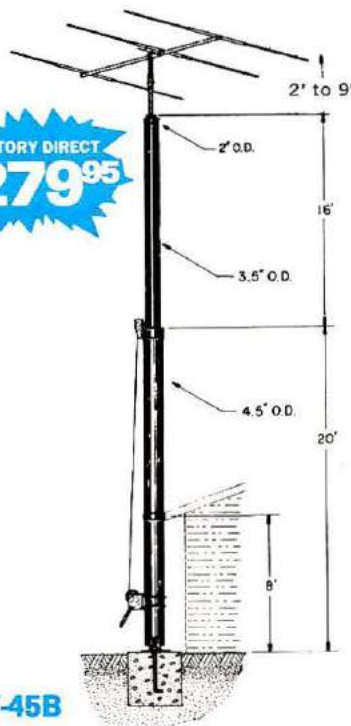

FACTORY DIRECT
\$489⁹⁵

NEW IMPROVED FEATURE

A new high strength carbon steel tube manufactured especially for Wilson Systems, is used for the new TT45B and MT61B. 25% stronger than conventional pipe or tubing. Tube size: 3.5" O.D. @ .095, 4.5" & 6" O.D. @ .120.

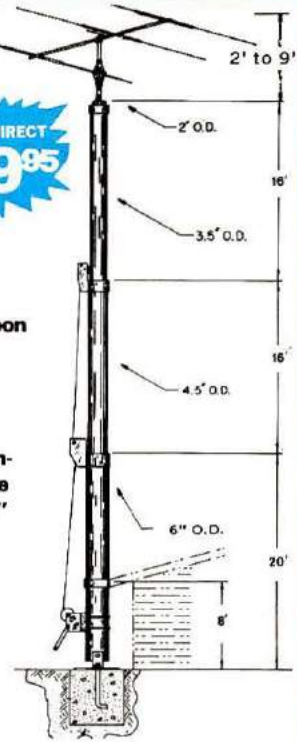

MT-61B

FEATURES:

- Is freestanding with use of proper base
 - Maximum Height 61' (will handle 17 sq. ft. @ 53 ft. or 10 sq. ft. @ 61 ft.) @ 50 mph
 - 1200 lb. brake winch
 - 4200 lb. raising cable
 - Total Weight, 400 lbs.
- Recommended base accessory: RB-61B, FB-61B

The MT-61B is our largest and tallest freestanding tower. By using the RB-61B rotating base fixture the MT-61B is ideally suited for the SY33 or SY-36. If you plan to mount the tower to your house, caution should be taken to make certain the eave is properly reinforced to handle the tower. If not, one of the base accessory fixtures should be used. (Requires 18"x18"x48" concrete.)

TILT-OVER BASES FOR TOWERS

FIXED BASE

The FB Series was designed to provide an economical method of moving the tower away from the house. It will support the tower in a completely free-standing vertical position, while also having the capabilities of tilting the tower over to provide an easy access to the antenna. The rotor mounts at the top of the tower in the conventional manner, and will not rotate the complete tower.

FB-45B ... \$114.95
FB-61B ... 169.95



ROTATING BASE

The RB Series was designed for the Amateur who wants the added convenience of being able to work on the rotor from the ground position. This series of bases will give that ease plus rotate the complete tower and antenna system by the use of a heavy duty thrust bearing at the base of the tower mounting position, while still being able to tilt the tower over when desiring to make changes on the antenna system.

RB-45B ... \$179.95
RB-61B ... 249.95

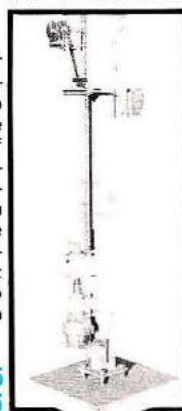

Tilting the tower over is a one-man task with the Wilson bases. (Shown above is the RB-61B. Rotor is not included.)

ORDER
FACTORY DIRECT
1-800-634-6898

W S I WILSON
SYSTEMS, INC.

4286 S. Polaris Ave., Las Vegas, Nevada 89103

NEW

ST64 - 64 ft. Stacking Tower
ST77 - 77 ft. Stacking Tower
CALL FOR INFORMATION

February, 1980
Volume 4, Number 2

T.H. Tenney, Jr., W1NLB
Publisher

James R. Fisk, W1HR
Editor-in-Chief

Editorial Staff

Thomas F. McMullen, Jr., W1SL
Managing Editor

Martin Hanft, WB1CHQ
Administrative Editor

Robert Schneider, N6MR
Joseph J. Schroeder, W9JUV
Alfred Wilson, W6NIF
Assistant Editors

James R. Wales
Art Director

Publishing Staff

J. Craig Clark, Jr., N1ACH
Assistant Publisher

T.H. Tenney, Jr., W1NLB
Advertising Manager

James H. Gray, W1XU
Assistant Advertising Manager

Harold P. Kent, WA1WPP
Dorothy A. Sargent, KA1BEB
Advertising Sales

Susan Shorrock
Circulation Manager

Cassette tapes of selected articles
from *Ham Radio Horizons* are available to
the blind and physically handicapped
from Recorded Periodicals
919 Walnut Street, 8th Floor
Philadelphia, Pennsylvania 19107

Microfilm copies
are available from
University Microfilms, International
Ann Arbor, Michigan 48103

Copyright 1980 by Communications
Technology, Inc. Title registered
at U.S. Patent Office

Ham Radio Horizons
is published monthly by
Communications Technology, Inc
Greenville, New Hampshire 03048
Telephone 603-878-1441
ISSN 0147-8818

HAM RADIO HORIZONS

CONTENTS

Antarctic Ham Stations	12
Jerrold A. Swank, W8HXR	
Taking Amateur Radio To School	18
Janice D. Shillington, N9YL	
Inexpensive Power for Lab and Shack	24
Hank D. Olson, W6GXN	
VOMs And Their Uses	31
John J. Edwards, WB2IBE	
Low-Cost, Low-Effort Antenna For 160	38
David E. Heil, K8MN	
Condominium Hamshack	43
Ethan A. Winning, WD6GKF	
A Script For Tower Installation	48
Michael R. Slepian, WB2LKO	
CB Goodies You Can Use for Hamming	54
Karl T. Thurber, W8FX	
Activities Calendar	76
Ad Check	78
Ad Scan	71
Advertiser's Index	78
Benchmarks	60
DX Forecaster	74
Focus and Comment	8
Horizons Locator	72
Newsline	11
Post Box	59
Product Showcase	63
Propagation Chart	75
This Month's Horizons	2
The View From Here	6

THE VIEW FROM HERE



The 1979 World Administrative Radio Conference (WARC) is now history, and as I predicted in an editorial almost a year ago, Amateur Radio remains in possession of the same high-frequency spectrum we've had for the past several decades; as a bonus, we have three all-new HF bands for the future. Thanks to long years of behind-the-scenes work by the International Amateur Radio Union (IARU), the national Amateur Radio societies, and interested Amateur Radio volunteers, the Amateur Radio Service went to Geneva very well prepared. These are the same people who remained optimistic about the outcome of WARC throughout the long years of preparation and deserve to be both elated and satisfied by the final tally. The Lord of Gloom and Doom who predicted a total debacle in Geneva was last seen skipping off to the Land of Oz with one foot in his mouth.

I first became aware of plans to pursue new ham bands at 10, 18, and 24 MHz more than five years ago, but quite frankly I considered the possibility of any new high-frequency bands as more pipe dream than reality. When W1RU announced the new bands at the Dayton Hamfest in 1974, most amateurs thought the pressure for new bands was simply a ploy to maintain the *status quo*; you know the old game: ask for more than you want so you can keep what you already got. Apparently the movers and doers of Amateur Radio who started preparing for WARC in the mid 1970s thought otherwise. A. Prose Walker, W4BW, Chief of the FCC's Amateur and Citizens Division in those years was instrumental in arranging for the propagation studies that were conducted to show how long-distance Amateur communications links would be greatly enhanced and made more reliable with new allocations at 10, 18 and 24 MHz; Prose deserves a great deal of praise — and thanks — for getting the WARC preparations underway at such an early date. Without his foresight and experience I don't think Amateur Radio would have survived WARC in such good shape. Amateur Radio is also indebted to the dozens of dedicated volunteers who served on the FCC's Amateur Radio Advisory Committees, often at great personal expense, and to the ARRL and IARU staffers who convinced other national societies to get their WARC preparations underway early and then coordinated those activities.

What about those new bands? What are their propagation characteristics? How soon can we expect to have them available for Amateur Radio use? To answer the last question first, it will be quite awhile before you begin hearing ham signals on these bands; probably 1982 for 10 MHz, and not before 1985 for 18 and 24 MHz. The long delay for the top two bands is because Amateur Radio stations will not be permitted to take possession of these *exclusive* frequencies until all existing fixed services have moved to new assignments; the transition will occur between July, 1984, and July, 1989, so it will be nearly five years at the earliest, and significantly longer if any of the present users feel like dragging their feet.

It may not be obvious, but the frequencies of the three new ham bands were very carefully chosen — each band is very near the geometric mean of the two existing, adjacent bands. This is optimum band placement for maximum propagation enhancement, so it should be possible to maintain long-distance radio communications for many more hours each day than is possible with our present allocations. For example, during the years of low sunspots when 20 meters goes dead in the evening, and 40 has not yet opened up, chances are good that 30 meters will still be open. Likewise, when 10 meters drops out, it's likely that 24 MHz will still be hot, and when no more signals are heard on 21 MHz, 18 MHz will probably be lively. In the mornings you can expect 30 meters to open slightly before 20, and the DX will be coming through on 18 MHz sometime before 15 opens up. When the sunspot count decreases, 18 MHz will still be in good condition on many days when 21 MHz is completely dead.

Practically all of the new rigs which use phase-locked loops already cover the new bands (although they are not presently programmed to transmit there); some will require simple modifications, but you can be sure the manufacturers are already working on them — and will have mod kits available by the time the new bands are opened to hams. Much of the popular older equipment has extra crystal sockets already built in, so this equipment can also be quickly placed on the new bands. Many receivers have a WWV position at 10 MHz, so you can check out the present activity on 30 meters if you want to; the older "hams bands only" receivers don't cover 18 and 24 MHz — and don't have extra crystal sockets either — so you'll need an outboard converter for listening in. We already have a *New Bands Converter* on the bench that covers all three bands; we'll get a complete description into the magazine just as quickly as possible.

Jim Fisk, W1HR
editor-in-chief



143.800 — 148.200 MHz Mobile Transceiver

Power to the mobile operators! This one is brand new, and it carries a powerhouse punch wherever you're going. ICOM unveils a full 25 watts of mobile power with the introduction of the new **IC-255A**. When you want increased mobile QSO range, ICOM delivers; and **nobody does it better.**

The microprocessor controlled **IC-255A** is a deceptively compact unit which packs more big, multifeature flexibility than any other ICOM mobile to date. This one offers a 5 channel memory, complete with memory scan, adjustable scanning speed, and auto-stop. The 5 channels can easily be written from any inband frequencies; and the scan function can be programmed to scan all 5 or only 2, stopping on any signal.

Like the other new ICOM transceivers, the IC-255A comes with 2 VFO's built-in at no extra cost. The radio is programmed to come up to power operating at 600Khz splits,

but it can be reprogrammed to any split of your choice. The dual VFO's and single tuning knob provide you with smooth, easy tuning in 15KHz or 5KHz steps.

The use of new low-noise, dynamic range junction FET's (for the RF amplifier and the first mixer) and helical cavity filters (for the antenna and RF circuits) provides excellent sensitivity and intermodulation distortion characteristics. A pair of high quality monolithic crystal filters and ceramic filters facilitates interference free reception reliability.

The new **IC-255A's** power is selectable 25W high or 1W low, yet it draws only 5.5 amps when transmitting in the high power mode. A directly amplified VCO output, without the use of multipliers or mixers, and a power module in the PA unit produce a very clean transmitted signal, with low spurious radiation. When you're in an RF trap, the **IC-255A** can get out the signal. To give your mobile FM operations big features with a power punch, give yourself the **IC-255A**.

HF/VHF/UHF AMATEUR AND MARINE COMMUNICATION EQUIPMENT



ICOM

ICOM AMERICA, INCORPORATED

Sales Service Centers located at:

2112 116th Avenue NE
Bellevue, WA 98004
Phone (206) 454-8155

3331 Towerwood Dr., Suite 307
Dallas, TX 75234
Phone (214) 620-2780

ICOM INFORMATION SERVICE

2112 116th Ave., N.E.
Bellevue, WA 98004

Z

Please send me: IC-255A specifications sheet; full color ICOM Product Line Catalog; List of Authorized ICOM Dealers.

NAME _____ CALL _____

ADDRESS _____

CITY _____ STATE _____ ZIP _____

You may send a machine copy of this form



FOCUS & COMMENT

If you haven't heard the good news from WARC by this time, take a moment to read Newsline on page 11 of this issue, or if you're not sure whether what you have heard is rumor or straight, there's the latest, as of mid-December.

It appears that we have some interesting chunks of spectrum to explore. There are possibilities aplenty in these new bands, not the least of which is a chance to follow propagation and the changing Maximum Usable Frequency (MUF) in closer steps as it moves up and down in reaction to solar activity.

Then, too, there's a whole raft of antennas to be designed, fabricated, tested, and talked (argued) about on the air and at hamfests and club meetings. Anyone for a 6-band quad or Yagi? Those of you who are adept at making traps and loading coils should have a ball, both in constructing the gadgets and in writing about them for publication (in *Ham Radio Horizons*, naturally).

Do you still have bare spots on the wall of your hamshack? How about covering them with certificates for 9-band WAC, DXCC, or, perhaps, 10-band WAS? The award hunters and certificate printers will be in ecstasy, and woe unto the contest-log checkers!

Equipment? Here, too, is an unequalled opportunity for the inventiveness of the Amateur to come to the forefront. Sure, there are a lot of new rigs out there that are adaptable to these extra bands with no more effort than obtaining a new synthesizer-programming chip from the manufacturer, or perhaps some minor wiring changes, and there'll be more new rigs produced. But, there are many, many older rigs that just require some suitable crystals to hit 30, 17, and 12 meters, and still others that will need some sort of converter to stretch their reach to new frequencies. Further, once you have the rig itself working on the new bands, you'll likely need a matching circuit to let it work with the new generation of "all band" antennas — more inductors, capacitors, switches, etc.

But, hold on a moment — don't go rushing down to your nearest equipment dealer and parts emporium, expecting to return home carrying the necessary goodies to add three new bands to your repertoire! There are a couple of clinkers in the sugar bowl, or whatever.

One is that the bands look good on paper, but we don't have 'em yet. Look closely at the timetable, and realize that it might be stretched — considerably. It is important to remember that the process of turning new bands over to the Amateur Service requires that, first, Congress must approve (ratify) the package from WARC, and, second, that the FCC must put the proposals into workable form, which includes Notices of Proposed Rule Making, hearings, and so on. Even if everyone is in favor, and all the hearings come off without a hitch, it will take time just from the sheer bulk of paperwork involved.

Added to this is the stipulation that all *present* users of those bands must have moved before Amateurs will be allowed to operate there. If the results of complaints about the Russian "woodpecker" are any indication, it could be a long wait before "all" present users go away.

Added to all this news about bands in the high-frequency area is recognition that Amateurs have earned a slice of the microwave pie, as well. This is an increasingly important part of the spectrum, especially where modern, high-speed digital or television signals are concerned. These are spectrum-gobbling methods of communication, and with the emphasis by government and business on "bigger, better, and faster," the value of a microwave spot will shoot up only slightly less rapidly than the price of gold.

Thus, it is a great feather in the Amateur's cap that he now has a spot to park his satellite's transponder and beacons. I suspect that chief among the factors leading to these allocations was the work done by AMSAT and allied Amateur organizations in many countries, proving that a working and useful communications satellite could be assembled at a price that would be considered "petty cash" by most agencies involved in space-age communications.

To all the world's IARU representatives, ARRL, AMSAT, and the many other people who spent the past five or more years getting ready for WARC, a hearty round of applause (standing, if you please).

Thomas McMullen, W1SL
Managing Editor

Even WEAK SIGNALS print clearly with a HAL Demodulator.

ST-6000 Demodulator \$659.00



ST-5000 Demodulator \$239.00



Pulling in weak or distorted signals with a HAL Demodulator is no problem. Even if the band is crowded.

With high-gain, wide-bandwidth limiters and extremely linear active detector circuits, both the ST-6000 and ST-5000 Demodulators convert RTTY tones into strong, readable signals that display bright and clear.

Tones necessary for transmitting RTTY are conveniently generated and receive filters and transmit tones are accurately set and matched to assure on-the-money transceive operation.

**HAL Communications and
amateur radio serving
the 1980 Winter Olympics
through W.O.R.A.N.
(Winter Olympics Radio
Amateur Network)**

Both the ST-6000 & ST-5000 offer these features:

Internal Loop Supply • Internal AFSK Generator with CW ID Tone • Internal Tuning Indicator • Autostart Motor Control • Line/Local Loop Control • TTY Machine Compatibility • RS-232 type DATA Interface • "High" or "Low" Tones • 120/240, 50/60 Hz Power • Normal/Reverse Switch • 170 and 850 Shift • Active Discriminator • Metal Cabinets for RF Shielding.

Special Features of the ST-6000:

Mark-Hold • Antispace • Automatic Threshold Control (ATC) • Decision Threshold Hysteresis (DTH) • Keyboard Operated Switch (KOS) • MIL-188 and CMOS Data Interface • Optional Oscilloscope Tuning Indicator • Crystal Controlled AFSK Tones • Active Input Bandpass Filter • Pre-Limiter AGC • Three Shifts (170 - 425 - 850)

Write or give us a call. We'll be glad to send you our new RTTY catalog.



HAL COMMUNICATIONS CORP.
Box 365
Urbana, Illinois 61801
217-367-7373

For our European customers, contact: Richter & Co. D3000
Hannover 1 • I.E.C. Interelco, 6816 Bissone/Lugano • Radio
Shack Ltd., London NW6 3AY • Erik Torpdahl Telecom, DK 3660
Stenlose Denmark

The engineering
breakthrough by

DRAKE

brings an entirely new state of the art
to worldwide radio communications...

solid state

TR7

synthesized hf
transceiving system

continuous coverage

0-30 MHz

continuous coverage reception — no gaps —
no range crystals required

160-10 Meters

Amateur Band transmission, including
capability for MARS, Embassy, Government,
and future band expansions



- ★ Sophisticated System Concept
- ★ Innovative Design Features
- ★ Straightforward Simplified Operation
- ★ State of the art performance now a pleasure

7 Line Accessories

• **RV7** Remote VFO • **PS7** 120/240V Ac Supply • **Aux7** Range Program Board
• **MS7** Matching Speaker • **NB7** Noise Blanker • **FA7** Fan • **SL300** Cw Filter, 300 Hz • **SL500** Cw Filter, 500 Hz
• **SL1800** Ssb/RTTY Filter, 1.8 kHz
• **SL6000** A-m Filter, 6.0 kHz • **MMK7** Mobile Mounting Kit • **TR7** Service Kit/Extender Board Set • **TR7** Service/Schematic Book.

- **Broadband, 100% Solid State Design.**
- **Exclusive Synthesized/PTO Frequency Control** — 1 kHz dial, 100 Hz digital readout. 500 kHz range pushbuttons.
- **Continuous, Wide Range Frequency Coverage** — 1.5 thru 30 MHz (zero thru 30 MHz with optional Aux7).
- **State of the Art "Up-Conversion" Receiver Design** — with high level double balanced mixer.
- **True Full-Passband Tuning** improves reception in heavy QRM.
- **Unique Independent Receive Selectivity** — Optional front panel pushbutton-selected filters.
- **Effective Noise Blanker** — true impulse-type performance.
- **Special High Power Solid State Power Amplifier** — diagonal heat sink allows internal mounting. Continuous duty on SSTV/RTTY with optional fan.
- **TR7 Internal Test Facilities** — "S" meter and built-in rf Wattmeter/VSWR Bridge.
- **Receiver Incremental Tuning (RIT)**

Specifications and prices subject to change without notice or obligation.

R. L. DRAKE COMPANY



540 Richard St., Miamisburg, Ohio 45342
Phone: (513) 866-2421 • Telex: 288-017

For a FREE Drake Full Line Catalog contact your favorite Drake Dealer.

NEWSLINE

ALL PRESENT HF BANDS, THREE NEW HF BANDS, and a new UHF band were allocated to the Amateur Service as WARC 79 finished its work December 4. Despite some gloomy predictions of a major frequency loss by the Amateur Service, it's now been confirmed that Amateurs — at least in the U.S. — did not lose one kHz in the HF spectrum but instead picked up all three of the desired new bands! In the VHF spectrum preliminary press-time reports, believed complete and accurate, show equally good news for higher frequency enthusiasts. Band by band, here's the rundown from WARC 79 on the new Amateur spectrum.

160 Meters: In Region 1, 1800-1850 shared with Loran until Loran shuts down at the end of 1982, 1850-2000 shared with Fixed, Mobile, Radio Location and Radio Navigation (1850-2000 not available for Amateurs in Mexico and much of South America). 1800-1850 will be available to Amateurs in Region 1 for the first time, on a shared basis with Loran until its shutdown.

80/75 Meters: In Region 2, 3500-3750 Amateur Exclusive with the exception of Mexican and some South American Fixed and Mobile users, 3750-4000 shared with Fixed and Mobile — except for much of southern South America, which excludes Amateurs 3750-4000, and Canada and Greenland, which reserve 3950-4000 for a future Arctic region broadcast service on a non-interference basis.

40 Meters: 7000-7100 Amateur Exclusive worldwide, 7100-7300 Amateur in Region 2 only with the stipulation that Region 2 Amateur operation must not interfere with broadcast in Region 1 or 3.

30 Meters (new band): 10.10-10.15 MHz with Fixed Service Primary and Amateur Service Secondary, worldwide.

20 Meters: 14.00-14.35 unchanged, with several others joining Russia in footnotes reserving 14.25-14.35 for Fixed Services.

17 Meters (new band): 18.068-18.168 Amateur and Amateur Satellite are Exclusive (with a Russian reservation for internal Fixed Service use), but with the stipulation that Amateurs won't be permitted to move in until after all present users have moved!

15 Meters: No change, worldwide.

12 Meters (new band): 24.890-24.990 Amateur and Amateur Satellite are Exclusive, with the same restrictions as 17 Meters.

10 Meters: Unchanged, worldwide

6 Meters: Unchanged, after earlier hope of some limited band being made available in Region 1 didn't materialize.

2 Meters: Unchanged (144-148 in Region 2, 144-146 elsewhere).

1.4 Meters: Amateur in Region 2 only, co-shared with Mobile and Fixed on an equal basis.

70 Centimeters: 430-440 MHz has Radio Location Primary, Amateur Radio Secondary in all Regions, with 435-438 Amateur Satellite. 420-430 and 440-450 shows Fixed and Mobile Primary in all Regions, but a footnote by the U.S. and several others allocates these additional frequencies to the Amateur Service on a Secondary basis. Similarly, 440-450 is allocated to Amateurs on a Secondary basis in a footnote by Canada and several others.

35 Centimeters (new band): A new UHF 902-928 MHz band, was allocated to Fixed, Mobile, ISM and others on a shared, Primary basis, with the Amateur Service Secondary. What this means to the Amateur Service in the U.S. is hard to predict, with interest high at the FCC in a new Personal Radio Service in this band.

At Microwave, Amateur Radio did lose 1215-1240 MHz but kept 1240-1300 with a satellite uplink subband at 1260-1270 MHz. The 2300-2450, 3300-3500, 5650-5925, and 10000-10500 MHz bands all remain Amateur Secondary as before, but with new subbands on all four for Amateur Satellite use. 24-24.25 GHz continues Amateur and Amateur Satellite, but we now have worldwide allocations at 47-47.2, 75.7-81, 119.98-120.02, 142-149, and 241-250 GHz with a good portion of most Amateur and Amateur Satellite Primary.

The New 30 Meter Band could become available for Amateur use as soon as January 1, 1982, but Amateur occupancy of the new 18 and 24 MHz slots probably won't occur for two to five years past that.

"VOLUNTEER AMATEUR EXAMS ARE ILLEGAL!", the FCC's General Council declared at the Commission's agenda meeting December 19th. The bombshell announcement came as the Commissioners discussed terminating Docket 20679, the Notice of Proposed Rule Making that would have required volunteer examiners to submit photocopies of their licenses when requesting an exam. The judgment appears to stem from recent Congressional concern that some government agencies were improperly expanding their staffs, without approval of Congress, by use of volunteers and contractors. When the legal staff reviewed the volunteer program in connection with Docket 20679, they concluded it is illegal and thus must be terminated.

What Effect Termination will have on existing training programs and U.S. Amateur growth, not to mention the added burden on FCC's Field Offices, remains to be seen. For the first three years of the Novice program its exams were all Field Office administered; responsibility for Novice exams has rested with the Amateur Service since June, 1954.

No Date Has Yet been set for the termination.

Jerrold Swank, W8HXR

Lifelines to ANTARCTICA

Amateur Radio provides communications to the world's last frontier

Although it's on the same globe as the rest of us, the Antarctic continent at the bottom of the world still isn't a part of the world the public knows and understands. We can understand it better if we think of it as another planet altogether; a piece of outer space somewhere between here and the moon. It can't be reached from the rest of the world for six or more months of the year. It has no native residents, and, even today, no one lives there. In the entire history of the planet, no human being has ever been born there.

That's the Antarctic, the highest, windiest, coldest, driest, and most desolate of the seven continents. The human race has lived on the other six continents for eons. It has kept its foothold on the seventh continent for only 24 years.

Two decades of human habitation have scarcely affected this desolate land. Only thirty-five "communities" dot the entire continent. Man has still set foot on only a small fraction of the continent, and is still able to live there only under "survival" conditions.



Further, with all of our technology, we can fly aircraft to the continent only during half of the year. During the other half, the continent is almost as remote from the rest of the earth as is outer space. No one can go there, no one can get back, and those who are there cannot travel about. Only four small parties have ever reached the South Pole by land, and only one party has ever crossed the continent on the surface.

Research conducted in the American Antarctic program falls into three broad cate-

gories: land, animals, and atmosphere. There are very few animals to study on the land itself. Of the fourteen species of penguin in the Southern Hemisphere, only two are found on the Antarctic continent — the tuxedo-clad Emperor penguin, and the smaller Adelie.

The Weddell, and several other species of seal, are found on the ice along the edge of the continent, and the large skua gull makes its nest near the penguin rookeries, where it can feed on penguin eggs and chicks. That's about all the life to be found along the shores of the continent. There's no wild-

life at all in the interior. Ironically, though, this barren continent is surrounded by some of the richest water on earth, teeming with tiny forms of life.

The stations

McMurdo Station is headquarters for the United States operations in Antarctica, on the shores of the Ross Sea. The summer population sometimes swells to 800, but during the austral winter the figure drops to less than 100.

All communications between the men in Antarctica and

home are handled by Amateur Radio. Just four stations operate during the winter. The station at McMurdo is KC4USV — it is now the only Navy-operated station. The rest are civilian and use KC4AA calls, which are assigned to the National Science Foundation. The KC4US- calls are assigned to the Admiral in charge of Antarctic operations, and the operators are any who are willing to devote time to handling phone patches one day a week. They are checked out by the Chief Operator, a Navy man.

There are Palmer Station, opposite the southern tip of Chile; Siple Station, about 600 miles closer to McMurdo; and the most widely known — South Pole Station, about 800 miles from McMurdo. South Pole Station is the highest, about 9,000 feet above the land, with nothing under it but solid ice.

There is nearly twenty times as much ice and snow in Antarctica as in all the rest of the world, including all the mountains and icebergs and ski slopes and snow and Arctic ice in the world. If it all were to melt, the water level would rise to the top of the Statue of Liberty, and you could take a boat into Pennsylvania.

Scott-Amundsen Station, at the South Pole, was first opened on January 23, 1957. Although it was built on the surface of the ice cap, its heat and weight caused it to sink 40 feet beneath the ice over the years. On January 9, 1975, a new and modern South Pole facility was dedicated after four years of construction. It is a gigantic aluminum dome, 164 feet in diameter and 5 stories high. Within the dome are three buildings. Another four structures are connected by enclosed walkways.

The Amateur Radio call at the Pole is KC4AAA. It is now a quarter of a mile from the Pole itself, but is moving, on top of the ice cap, toward the Pole at

a steady rate. In five years, KC4AAA will be directly over the South Pole, and in ten years it will be a quarter of a mile on the other side.

The South Pole is one of the strangest places on earth. Even from an aircraft, the flat, monotonous ice cap stretches as far as the eye can see in all directions. The runway that serves it is 1,400 feet long, with 2,000 miles of overrun.

“There is nearly twenty times as much ice and snow in Antarctica as in the rest of the world . . .”

If you walk around the barber pole that marks the South Pole, you pass from today into yesterday, and back into tomorrow by walking through every time zone. You can walk “around the world” in a few seconds. Your watch is always right at the Pole, even if it is stopped, since it is every time on the 24-hour clock at the same time — where all the time zones converge. Every direction is north, and every wind is a north wind.

Oddly enough, winds at the South Pole are never more than 45 miles per hour — the highest velocity so far recorded — although temperatures go to more than 100° below zero!

Palmer Station is at the tip, and Siple Station at the base, of the Palmer Peninsula, on the side of the continent toward South America. A cluster of various Antarctica Treaty Stations are scattered around the tip of the peninsula. These are all so far from other American bases that they are supplied from South America rather than from the New Zealand-McMurdo route.

Palmer Station, like McMurdo, is at ground level. It is much warmer than the rest of the Antarctic continent, and the men at the other stations refer to it as “the banana belt.”

I listened to the christening of the Palmer Station back in 1965, and I remember the operator saying that one man had the job of keeping the skua gulls out of the pool of drinking water obtained from the melting glacier. Better arrangements have been made since then.

The continent is over 3,000 miles across, and larger than America and Mexico combined. Many times, Palmer Station has had trouble communicating with McMurdo, and I used to relay for them. Their call is KC4AAC.

Siple Station has a much greater snowfall, with about 5 feet each year, and the old Siple Station, after five years, is now 45 feet below the top of the snow. High winds help pile the snow up in drifts.

Siple Station is the newest, and is different from the others: It is modular in construction. In fact, it is so modern that some of the phone patches to home are now handled by satellite. It is on about 7,000 feet of snow and has a 13-mile-long antenna — for long-wave research. Siple's Amateur call is KC4AAD.

There is no law in the Antarctic except for treaty agreements. In fact, to avoid pileups and breakers, I used to transmit on 7299-kHz, lower sideband, and they would transmit to me on 7308-kHz from South Pole Station. The FCC has no jurisdiction there.

No plants or animals may be imported which might change the ecology. In one incident, one of the men smuggled in a black cat. They talked about it on the air, and the cat was ordered destroyed. They promptly named the cat “Catsafrakus” in honor of John Katsafrakus, the project officer in charge of Antarctic operations.

Mail can come out only during their summer, so QSL cards must wait until November for winter contacts. Most of the stations have QSL man-

agers from whom you can get quicker verification *if* you enclose an S.A.S.E. Each station gets up to 2000 cards in a year, and some operators take their cards home when they leave, fully intending to answer them all. However, they may go to another station and forget to reply. It's better to use the QSL-manager route. Antarctic operators are enthralled with ham radio when they are lonely, but it wears off when they see their families. You would do the same.

In all fairness, some actually visit the hams who have helped them, and some phone me when they get back and thank me. Just be glad that you can help such deserving men. I know that nowhere are phone patches so appreciated.

The hams and their equipment

I have talked to some of the hams who operated there, both at McMurdo and South Pole Station. One who went back each year from 1969 to 1974 for the winter-over season was Robert M. Conner, now WA1SDT, but at that time WB2BCJ/KC4. During the austral summer of 1974, which is our winter, Bob and I talked on 75 meters when he was at Davisville, Rhode Island. That was the headquarters of Antarctic Communications. I had tried for years to get them to use phased verticals, because their 40-meter signal was one of the weakest from the continent.



Bob, WA1SDT (then WB2BCJ) enjoying one of his feet-up-and-relaxed chats with the folks back home from KC4USB, Byrd Station, in 1971. The feet holding down the Collins gear behind Bob belong to an unidentified relaxee.

Since almost everyone goes there for only one season, there was no one who went back to try out the system. I discovered that Bob was going back, and we planned to have him install four 14AVQ antennas in an array consisting of two verticals a half-wave apart, with a similar pair a quarter-wave behind them as driven reflectors. The story of this array was published by *ham radio* in May, 1975. The improvement was dramatic, and made it possible to use 40 meters the year round instead of just from April to November. The array was installed in February, 1974. They built a new building at the base of the new array, and this was called "Hamshack III."

Hamshack III was a section of a standard T-5 hut. The outside dimensions were 24 x 20 feet. The T-5 is a plywood-and-fiberglass sandwich three inches thick, which comes in 4 x 8 sections and is easily erected in the polar cold. The interior is divided into two sections, the entrance, toilet, and storage areas, and the shack itself. The usable floor space in the main part of the shack is 400 square feet.

The building is set about three inches off the ground for heat conservation. In addition, the standard T-5 floor is covered with 3/4 inch plywood and overlaid linoleum. This helps insulate the floor and prevents cold feet. The walls are covered with white acoustic tile, a combination sound-deadening and insulating measure.

Bob installed all the electronic equipment, as well as all of the audio patch panels for the operation of the Amateur Radio desk, called "AMRAD," and the MARS desk across the room.

Hamshack III contains two complete operating positions. Each has a Collins KWM-2A transceiver, 312-B5 station control, 516-F2 power supply, and 180-S1 antenna tuner. The AMRAD console has two phone-

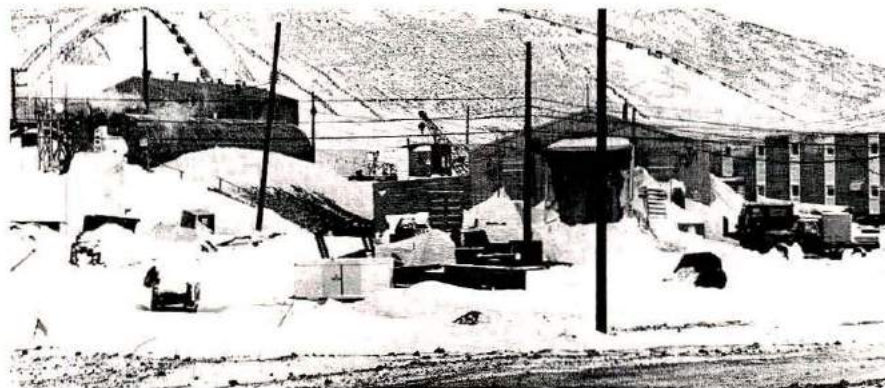

Beautiful downtown McMurdo Station, where a sign says, "So you wanted a Southern vacation?"

patch lines, so that one call can be in progress and a second one on standby, ready to go into the patch at the flick of a switch. The linear amplifier on the AMRAD rig is a Collins 30-S1, using a single 4CX1000A for a final.

The MARS rig has a Henry 2K-4 for an amplifier, using a pair of 3-500Zs for the final push. The AMRAD rig is used exclusively for voice operations and the MARS rig for both voice and RTTY.

In addition, the shack includes the following equipment located between the two consoles:

AN/UGC6 Teletype — used for tape cutting and transmitting

TT-176 Teletype — used for receiving RTTY

R1051D/URR receiver — primary receiver, used for RTTY and frequency calibration

R390A/URR receiver — backup receiver, also used for diversity reception

URA-17 frequency-shift converters — used for RTTY receiver and to monitor outgoing signals

TH-39A/UGT audio-tone generator — used to produce tones for AFSK, variable shift (narrow- and wide-shift signals)

USM-207 frequency counter — for checking width of shift in outgoing RTTY signals, and also used to measure exact frequency.

Bob's most memorable experience of his years "on the ice" was July 23rd, 1974, when an ice storm hit the station. The winds were battering the shack, and getting stronger. Radioman first-class Doug Wright was alone on duty at the time, and, when it became evident that disaster was about to strike, Doug asked for help. A driver



The Amateur Radio station at KC4USV, McMurdo Station (U.S. Navy photograph).

named Zimmerman volunteered to rescue Doug. All that could be used was a front-loader, and the road down was on the edge of a steep, icy hill, so Zimmerman scraped the front-loader's bucket along the side of the hill to keep from slipping down the hill as it descended, and he reached Doug just in time. Shortly afterwards, the wind tore the roof, back wall, and half of each side wall completely off. The only part of the structure left was the front and about 12 feet of each side wall.

The equipment, although packed with snow and fine gravel, did survive, and was made operational in a few days.

The antenna remained intact, except for one guy wire which was broken, and the coax was pulled completely out of one of the UHF connectors.

Operation was resumed from Hamshack II, the "old" location about a quarter of a mile away, with an emergency antenna of a pair of phased verticals. It was October before the demolished building was replaced.

When Hamshack II was built, it was the scene of a "happening" which Bob remembers well. Someone left the door of the building open one night and it became completely filled with snow. It took two days to clear the snow out of the shack, but the equipment (which was rescued first) was quickly put in operation in Hamshack I.

One of the men I used to run phone-patches for was another Bob — Bob Smith, now WB6VAK. While he was at South Pole Station he was not a ham, but was determined to become one. He practiced code by working Novices at night, and many a Novice was shaken up when he found he was talking with the South Pole. No license is required in Antarctica.

When he returned, he took the exam and became a General-class licensee. An astonishing fact was that his mother, who wanted to talk to him direct when he was assigned to Greece, also

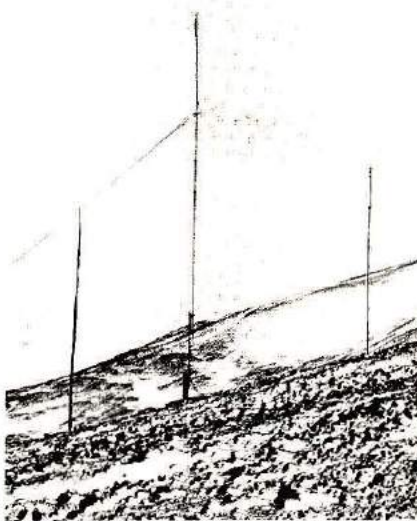

McMurdo Station's phased verticals — 14AVQs — as described in *ham radio* for May, 1975 (U.S. Navy photograph).

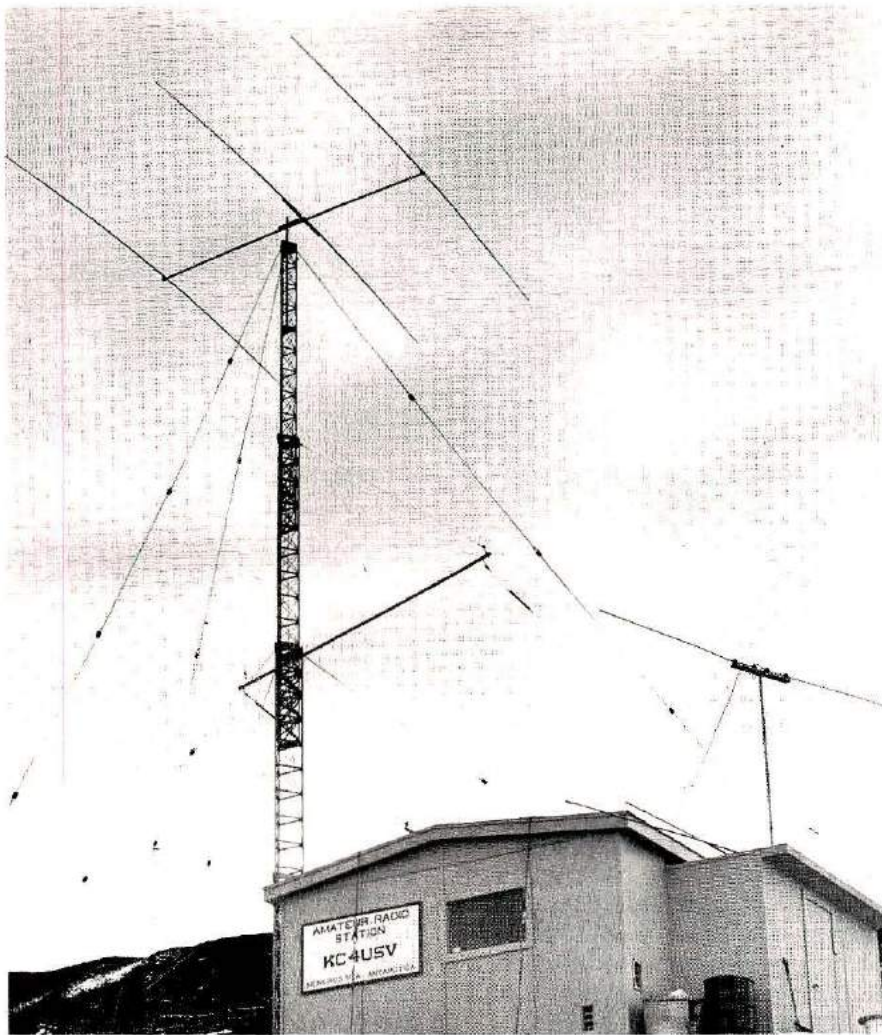

The "hamshack" and MARS-station building at McMurdo Station, with a well-guyed tower and other antennas (U.S. Navy photograph).

“Ship captains from the Far East . . . used to stop and see her, and thank her for the phone patches. . .”

Messages from home

When you are away from your family and loved ones for a full year or more, ham radio is essential for your morale. The Navy RTTY and CW circuits can send occasional messages for you, but hearing your wife's voice once or twice a week and knowing instantly that she is okay is much better. Needless to say, the morale-building is as great for her.

Even so, there are times when it doesn't help much. Take the case of Fred and Arlene, who were talking via a phone-patch run by Charlie, K1GZL, of Berlin, New Hampshire. Charlie was running traffic at the same time I was, back in the 1960s, and he had a great antenna and fantastic signal into "the ice." He ran mostly McMurdo Station traffic, while I ran traffic for South Pole, Byrd Station, and Eights Station. McMurdo had more men than the rest of the stations put together, and had a great load of traffic.

Fred would talk to Arlene and, for several months, all they would talk about was how much they loved each other, and about their marriage plans. They discussed who would be her bridesmaids and his best man, and how they would be married as soon as he returned from the ice. His voice was always full of anticipation.

One day Fred broke his leg, and ended up with the leg

became a ham. She asked me what she could do while Bob was in Greece, and I told her that she should buy or rent an Instructograph, and start studying. She did, and got her Novice ticket in about a month, and her General in four months, and was licensed before Bob was! She had no previous knowledge of radio, but a lot of determination. I was told that she shut herself up in a room with the code machine and copied for hours each day. She got a beam and tower, and soon became a big wheel in the Pacific DX net. Ship captains from the Far East and Pacific used to stop and see her, and thank her for phone patches she ran for them while they were at sea. This shows what determination can do to make you a ham.

I worked Bob three days a week for three years, on 15 meters, while he was in Athens, and when his mother, Susie (WB6UVU) could not copy him, I relayed with a tape recorder.

Bob is now with the Coast Guard on an Alaska run, and his mother still runs patches for the crew of his ship. She has become an ARRL A-1 operator.

Some Amateurs take their own gear with them and operate as portable KC4, and some of these are away from McMurdo Station on scientific jaunts, and are thus in touch with the States at all times. Even snow-cats on the traverse to South Pole Station from Byrd Station have operated 20 meters from their tracked vehicles.

suspended in a cast in the McMurdo Infirmary. He put through a patch to Arlene, and was relieved to hear her voice while in his uncomfortable position, until she said, "It's good to hear you again, and I am sorry about your accident, but there's something I have to tell you. I am getting married in three weeks. Over." "What did you say? Over." "I'm getting married in three weeks . . . I met this sailor a few weeks ago. I'm sorry, Fred."

What a letdown that patch was!

Charlie told me about a couple of others. Leo used to talk with his wife, Alice, from South Pole Station. In a sort of joking way — or was it? — she would say, "Leo, I can't wait till you get home so you can walk the dog, pay the bills, help me fix my hair, and take care of the yard. Over." He would come back a bit sheepishly and say, "Yes, dear." Then she would continue. Charlie said he wondered sometimes if Leo didn't hate to leave the ice.

Then there were Judy and Duffy. Judy was in Rhode Island and Duffy at South Pole Station. One night Judy said to Duffy, "It will be a great relief when you get home so we can start manufacturing babies." Charlie said he nearly split his sides.

One of the operators (a third Bob), Bob Smart, at Eights Station, (which is near where Siple is now, but has been closed since 1965 because it collapsed under the weight of snow), said that if he hadn't known he could come up to the station and talk with me every night he never would have made it through the tour of duty. He was the cook. He said there were 500 pounds of frozen Maine lobster left at the Station when it closed, as he was the only one who liked lobster. Each station keeps about five years' supply of food on hand, in case there is a war and access to the Antarctic is cut off.

When Bob came home to Green Cove Springs, Florida, I called him one night from my motel in Jacksonville. He said he would be right up, and arrived about 1:00 AM. I told him we could wait until the next morning, but he said he had to see me as soon as

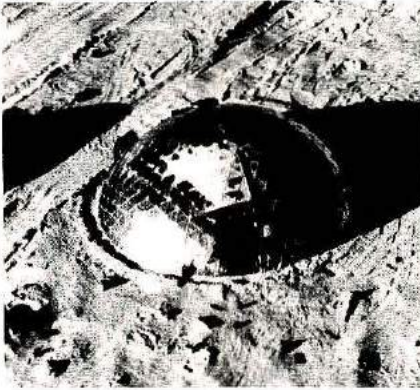

The photograph above is of the new South Pole Station with its geodesic dome that protects the living and working quarters from severe weather.

possible, after talking to me every night for a year. We enjoyed talking for several hours, and I visited him at home a few days later. I learned a lot about the Antarctic experience.

Working the stations

Although they sometimes move frequency for better reception, in general, KC4USV at McMurdo Station is at 14.260 MHz from about 0600 UTC until as late as 1000.

South Pole Station is usually at 14.320 MHz, with Siple and Palmer at about 14.310. However, at times any or all of them may be at a different frequency.

McMurdo sometimes moves up to their old frequency at 14.285 MHz to avoid the QRM from the Pacific DX net at 14.265 MHz.

South Pole, Siple, and Palmer often start as early as 0400, and, since there are fewer men there, will quit in a short time. After that, some of them work DX or just listen for Amateurs who want KC4 contacts.

It is best not to try to get contacts while they are running

traffic, as they never know when the band will drop out, and they want to take advantage of the good propagation.

Ask them questions and tell them the news and the sports results, but don't take all your time telling them what you are running; they couldn't care less, especially those who are not hams, but may be bulldozer operators or dentists.

McMurdo is on New Zealand time, and when it is 0800 UTC it is 8:00 PM there, tomorrow. They work a full day, even as we do, and usually eat around 5:30 PM and get to the radio room at about 6:00 PM, which is 0600 UTC.

The men who run patches want most of all to have someone at home, in "the real world," to talk to and get news from. They run patches to get the use of the radio.

The fifteen years I spent running patches for the Antarctic were the best years of my radio life. Even now, I often go up to 20 meters at night and say "hello" to the men in McMurdo Station. I get sort of homesick for the sound of the easily recognizable signal from the ice. Often, the band will be completely out, but the signals from the Antarctic will still be coming through.

They made me an honorary member of the South Pole Society — the only one who had not actually set foot on the South Pole; they sent me a large membership certificate. I received a QSL card made from a 6 × 12-inch section sawed out of the "90 South Bar" when the old station was dismantled, and it was addressed and a stamp affixed, with the words burned into the varnished, 2-inch thick wood — probably the heaviest "post card" ever mailed. I value it highly.

Talking with the men and their wives makes you feel that some of the world is still made of normal people. They love their family and miss them, and say so for all the world to hear.

HRH



A Mode To Share

BY JANICE SHILLINGTON, N9YL

We were all children once. Caught up in the everyday grind of living, we forget how it was to be a child. How serious a problem can be for a child, yet we "older" ones, in our wisdom, know it is nothing at all. We think as adults; we cannot comprehend the trials and tribulations of being a child unless we reach far back into our memories. Flash — I can still picture a boy named Paul being chased around the room by our teacher with a

ruler in her hand. I can remember the anguish caused by homework not quite finished, or forgotten. (Will she collect it? What will she say?) I can remember the sales ladies (and they still do it today) helping the adult, although the obviously waiting child was there first. The adult was important; the child was not. It's not easy to grow up.

Now, ask yourself, what in the world does this have to do with Amateur Radio? A lot. Think, for a moment. Children are our future; children are not children very long.

Many hams that I know started Amateur Radio at early ages; 12, 13, 14, 15, etc. They found something interesting and worthwhile to work at, have fun with, and be — not a child, but a ham. An interesting part of Amateur Radio is that everyone is equal. Your age or your sex doesn't matter, only your mind and your personality — the real you. And, of course, there's your radio signal. The radio signal doesn't care who you are or what you are. The more knowledge you gain, the better the signal can be. Money is always helpful, but it's not the key factor. Your intelligence, and application of it, is what makes Amateur Radio what it is. It's not just a matter of sending in your money or application and there is your license. You have to work to get an Amateur license. Anyone who has the knowledge (or can retain it at least until the exam is taken) deserves to have an Amateur Radio license — be that person 5, or 50, or even 21 years old, as I am.

Amateur Radio has much to offer everybody. The scientific type who loves to tinker has a home in Amateur Radio; the organizer who can take charge and get results has many opportunities in Amateur Radio (from officer of radio club, to Amateur-Radio Emergency Service coordinator, to Field-Day chairman). The ragchewer who loves to pass the time of day in friendly conversation need never be lonely in Amateur Radio.

But how do you get into Amateur Radio? First of all, you have to hear about it to even know such a thing exists. I didn't learn about Amateur Radio until I was 26 years of age (this is a paradox, since I am still 21). I lived, went to school, worked in the business world, married, had two children, tried to keep up with world issues, voted. In other words, I was an average, normal, active citizen, but I had never heard about Amateur Radio. I had a vague impres-

sion that hams were people who played with radios.

The young ones

W9JTO learned about Amateur Radio at 12 years of age from a neighborhood ham. WB9UQX became interested from seeing the ham stations at boy-scout camp. WA9EYY became interested in Amateur Radio when his new stereo set kept picking up 160-meter ham signals; he talked his father into buying him a \$35.00 Knight radio set and became a ham at 14. WB9ODF received a crystal set to play Flash Gordon with at nine years of age. From there, he went to SWLing and then to Amateur Radio at 14. WA9JMN became interested when he noticed a strange group of teenagers who ran around the south side of Chicago with No. 2 coffee cans affixed to their bumpers on their cars, calling themselves "The Shiburbun Mobileers." He was self-taught, and earned his Novice ticket at 13 years of age by reading and listening. At age 15 he passed his General the first time around.

If only . . . I wonder what would have happened if only I had learned of Amateur Radio



A demonstration of Amateur Radio is always an attention getter, and the simplicity of using a hand-held transceiver and the local repeater makes it easy.



Amateur signals travel all over the world, and touch down in distant and exotic places. A globe or world map, and a collection of QSL cards will get the point across that here is a fun thing to do.

when I was younger, in grammar school or high school. Many high schools now have Amateur Radio club stations, but mine, Oak Park and River Forest High in Illinois, had over one thousand students and many different clubs, such as Biology, Stamps, Photography, Railroad, Debate — but, alas, no Amateur Radio Club. Many times ham friends have said to me, "If only I had heard about Amateur Radio sooner . . . all the time lost and fun I missed." When you have a good thing, you want to share it — for in sharing it, it grows.

Openings

Some people do not care in the slightest about radio — Amateur or any other kind; their minds are closed. I don't believe I have ever met a child with a closed mind. Just the opposite. Those of you with children know that they are always asking questions. (When you're a mother you work toward the day when your child learns to talk; after a short while you long for the quiet times when they are not talking.) A child has an inquisitive mind. The more this is

developed, the better it is for all of us. Education is the process of answering the inquisitive mind, preparing the child in the basics of living in this world. What better place to share Amateur Radio?

I don't mean teaching Amateur Radio, but rather talking about Amateur Radio; telling the children that it exists. Recently, at the doctor's office, I received the results of his examination. After five minutes of explanation, I asked him to tell me again, in English. The same thing happened with my daughter's orthodontist. He gave me a very detailed explanation with words common in his field, but beyond me. I told him also, "Please, again in English." In other words, in grammar school, you do not have to go into detailed explanation of Ohm's law, capacitance, etc. You are not there to help them gain a license. You are there to open a door. You say, "Hi! Good afternoon boys and girls. I am an Amateur Radio operator. This is Amateur Radio."

A child invariably mentions that his father is in CB, has three radios, and gigantic

MORSE CODE

IN THIS CODE

••••• BECOMES C

••••• BECOMES A

••••• BECOMES T

•••••	•••••	•••••	•••••	•••••	•••••	•••••	•••••	•••••	•••••
•••••	•••••	•••••	•••••	•••••	•••••	•••••	•••••	•••••	•••••
•••••/•••••/•••••// BECOMES CAT					•••••/•••••/•••••// BECOMES RUN				

A	•••••	J	•••••	S	•••••
B	•••••	K	•••••	T	•••••
C	•••••	L	•••••	U	•••••
D	•••••	M	•••••	V	•••••
E	•••••	N	•••••	W	•••••
F	•••••	O	•••••	X	•••••
G	•••••	P	•••••	Y	•••••
H	•••••	Q	•••••	Z	•••••
I	•••••	R	•••••		

1. What goes oom oom oom ?

•••••/•••••/•••••// •••••/•••••/•••••// •••••/•••••/•••••// •••••/•••••/•••••// •••••/•••••/•••••// •••••/•••••/•••••//

W A T M K I O G B U C K ?

2. What's the largest jewel in the world ?

•••••/•••••/•••••/•••••/•••••/•••••// •••••/•••••/•••••/•••••/•••••/•••••//

B A S E B A L L D I A M O N D

3. What has 18 feet and catches flies ?

•••••/•••••/•••••/•••••/•••••/•••••// •••••/•••••/•••••/•••••/•••••/•••••//

B A S B A L L T E A M

4. What runs, but never walks ?

•••••/•••••/•••••/•••••/•••••/•••••//

W A T E R

5. What has a head and tail but no body ?

•••••/•••••/•••••/•••••/•••••/•••••//

A C O I N

6. What has legs but cannot walk ?

•••••/•••••/•••••/•••••/•••••/•••••//

A T A B L E

7. What is yours and no one else's ?

•••••/•••••/•••••/•••••/•••••/•••••// •••••/•••••/•••••/•••••/•••••/•••••//

Y O U R N A M E

A simple program to get the students involved in learning Morse code will make things run smoothly, and instead of talking to your audience, you're sharing your world with them.

antennas. I always answer, "Yes, that's nice. But this is Amateur Radio. You should tell your father about it. Amateur Radio and Citizen's Band are two completely different things. If you learn nothing else today, I want you to remember that. In Amateur Radio you have to earn your license. (I pass around a copy of my license.) You must take a Morse code test and a basic theory test. A child as young as 5 has earned his Novice, or beginner,

license, — "ticket" in ham talk. And, there are many children of 11, 12, 13, and up who already have their licenses. In Citizen's Band radio you are allowed to talk to local people — right around this area. Amateur Radio is both local and international. Do any of you know what international means? National means what concerns a country or a nation, such as the United States — like national security. A nation is an individual country. International

al means between or among nations or countries. Amateur Radio operators can talk internationally, between other countries all around the world."

I show them my Wilson Mark II hand-held transceiver, since my low-band gear is not portable.

"This is called a "handheld." This radio is used for local communications. I can talk with this small radio, going through a repeater station, about 60 miles.

"Your mouth is like the transmitter. It sends words through the air to your ear, which is like the receiver. You can't see or touch my words, can you? (With luck, they all answer no.) In Amateur Radio the words are put on radio waves that you can't see or touch. (If you're talking to an older grade you might mention light waves.) The transmitter sends the words out through your antenna. The message is picked up by my antenna, and is sent to the receiver which "hears" your messages and sends the words over a speaker."

Then I proceed to the classroom globe. Showing the globe, I explain about the layer of gases about 250 miles above the earth. With visual demonstration, I show how the signal bounces off the layers and goes back to earth, with my finger landing in any random place, as would a radio signal.

"Where the signal goes depends upon how thick the gases are, and what the spots on the sun are doing. This is how Amateurs can talk internationally. You do not need much power, but Amateurs are allowed to use 1000 watts; Citizen's Band is allowed only 5 watts."

On my poster, I have in big print: Amateur Radio is 1) Public Service; 2) Advancing the Radio Art; 3) International Goodwill; 4) Reservoir of Trained Operators. On another poster I have *Ham Radio Horizons* magazine clippings of



Students really like to "beep" the Morse code, and a few simple things they can do will produce amazing results. They'll remember sending their name in code for a long time.

pictures from the Guatemalan earthquake, and I describe how Amateurs help in emergencies. On another poster, I have pictures of OSCAR, again with clippings from *Ham Radio Horizons* magazine, and tell the children that, instead of your signal hitting the ionosphere it hits the satellite going around the earth. But, you must calculate, or figure out, when the satellite will be over your station.

The QSL cards are a big hit. I state my call and write it on the blackboard, explaining that N is the sign for the United States. "Anyone in the world hearing the N will know that my call is an American one. The nine tells that I live in either Illinois, Indiana, or Wisconsin. (The ARRL WAS map clearly shows the sections). The YL is just letters from the alphabet, but no two people can have exactly the same call. Your call is your own, and is even more important than your name.

You must use your call on all contacts that you have on the radio. You are not allowed to talk business or take money for any Amateur contacts. There are other radio services that are

licensed just for business."

I pass out my favorite QSL cards, explaining that ZL means that the station is in New Zealand, HB means that the station is in Switzerland, JA means Japan. I tell stories that

are interesting with the QSL. "I was talking with a ham in Japan. I told him that he was talking to yesterday. Can anyone tell me why I told him that?" Usually, someone will answer that when it's day in Japan, it's nighttime in the U.S. I go on to say that Amateur Radio works 24 hours, day or night. Someone is always there, somewhere in the world, to talk with you. If it is an older class, such as the fifth grade, you could discuss the international date line, and explain Greenwich Mean Time. I'm sure every Amateur worth his salt has some story to tell. Anywhere over a few hundred miles away is "DX" to these kids. I also show them my interesting stamps that I've collected through Amateur Radio.

The Morse code is very fascinating to the children. When they come up to try the practice oscillator and an old key, they do it almost reverently. I have them first try a dit, and then a dah. Each child in the room tries to do either his initials or first name, depend-



They may have "mike fright" at first, but they'll love it anyway — and talk about it for weeks. You can almost always find someone on the local repeater to go along with the demonstration.

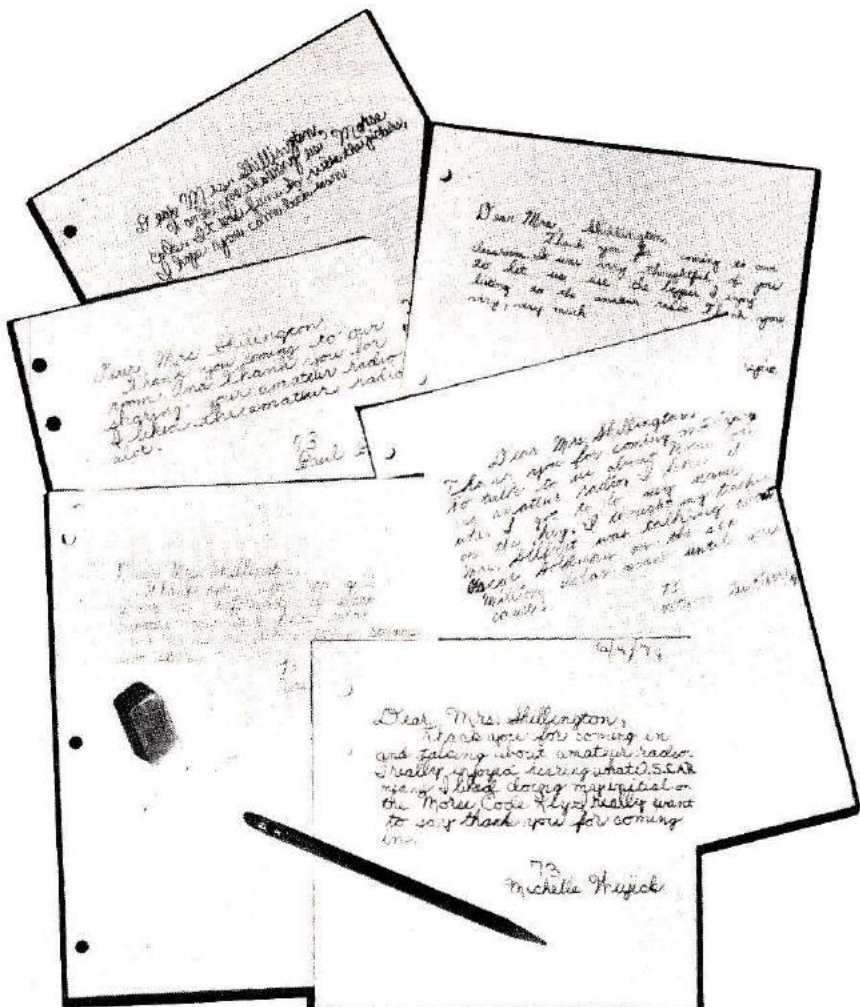

Part of the reward for you, as a "lecturer," is the thanks you receive after the demonstration and talk. The letters and notes you get will do wonders for your self-confidence.

ing on how many students are in the class. The classes are really attentive. They can hear when the letters are done right or wrong. If the child has too hard a time with code, we work on it together. It's such a simple thing, yet you can feel the excitement in the air. The children are so thrilled to touch the key and "do" Morse code. One third-grade teacher made up a paper with the Morse code on it before my talk. When I sent some letters they really caught on quickly. I did a little at about 18 words per minute, and one little girl in the back of the room copied the word I sent! (My husband claims she must have had ESP.)

The highlight is an actual Amateur-Radio transmission. I

explain that my handheld has a transmitter (which sends the signal) and a receiver (which hears the signal), all in one unit called a transceiver. I have found that it's best just to call CQ and take pot luck. I have almost always had someone call back. I surprise the hams by telling them that they are talking to about twenty-five school children, and to please tell the class about Amateur Radio. If you could only see the children's faces . . . eyes glued to the radio, ears listening so intently. (If you had low-band portable equipment that could be set up in about five minutes, that, too, would be exciting.)

Was that so hard? Yes, if you're faced with a group of eager 8 or 9 year-olds, waiting

to learn about Amateur Radio. Can you, an intelligent, articulate experimenter and Amateur, simplify Amateur Radio enough to interest a child? If so, you can bet your buttons that you'll be a teacher — even if it is on a short-term basis (one hour).

If you are a parent, this is a golden opportunity to share yourself with your child, and to enter into his world. There are times when being a ham means peace and quiet, a time when a "Do Not Disturb" (imaginary or otherwise) goes on the door. However, in going to your child's class you are opening the door and sharing yourself with your child; opening a door to better communication. Besides, they'll be proud of you. At this age, a father is so greatly admired: it's their Dad coming to school (and not to talk about report cards!). Childhood memories are precious. A parent/child relationship is something like putting your money in the bank; the more you put in now, the more interest you will collect the rest of your life.

If you are not a parent, you can still have fun. Grandpas, aunts, uncles, or older brothers are always in demand. One good point for you unmarried hams is that there are many young, pretty school teachers.

Children see things in a different light. One of my special moments happened unexpectedly as a nine-year-old boy, Octavio, was helping me carry my materials to the car. One of the teachers in the hallway asked what all that was. Octavio answered in a proud, clear voice, "That's Amateur Radio."

A very small percentage of our population has any idea what Amateur Radio is. If we don't educate the other, large percentage, who will? Without "starry-eyed and enthusiastic Novices" in our future, Amateur Radio will be like an exploding star. Once very bright, then . . . no more.

HRH

I-800-2228-4097

CALL TOLL FREE

Hy-Gain 3806 2-Meter Hand-Held Amateur Transceiver

SPECIAL PRICE \$109.95

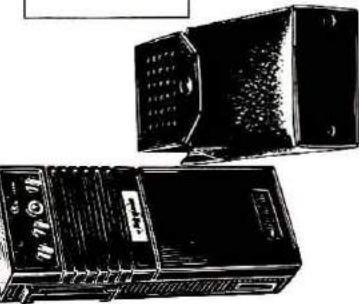

- Low cost, 8-channel hand-held provides search voice transmission over short to medium distances
- Sharply tuned on-frequency selectivity in the RF amplifier stages plus P.E.T. in the 1st and 2nd mixers
- Immunity to out-of-band signals
- Interchangeable microphone
- Separate microphone and speaker elements for enhanced audio
- Internally adjustable mic preamp—3 Hy-Gain enclosure
- Specially gasketed case seals out water, dirt and corrosion and an
- Impact resistant ABS plastic case—ribbed for non-slip grip
- Top-mounted controls for instant access

ACCESSORIES:

Model No.	Description	Price
8817	Beard Battery Pack	\$31.95
1164	Low In Fuse Pad	\$44.95
1106	RF Battery Charger	\$ 9.95
1106	Capacitor - Lighter Angular Grid	\$ 3.95
1110	Crystal - 14.4 MHz	\$17.95
1111	Crystal - 14.4 MHz	\$ 9.95
2094	Rubber Duck Antenna	\$ 5.95
	Crystal Certificates	\$ 1.95

PLEASE ENCLOSE \$2.00 FOR SHIPPING AND HANDLING PER UNIT.

CALL TOLL FREE

I-800-2228-4097

for Quality Ham Radio Products at Discount Prices

- | | | |
|-----------|---------|-----------------|
| KENWOOD | MIRAGE | E.T.O. ALPHA |
| YAESU | SWAN | VHF ENGINEERING |
| DRAKE | TEMPO | BERK-TEK CABLE |
| ICOM | TEN-TEC | ROBOT-SSTV |
| AEA | MIDLAND | SAY |
| PANASONIC | CDE | SHURE |
| BENCHER | AUTEK | TELEX |

Our Mail Order Hours (CST)
 M-F 8 am to 10 pm
 Saturday 8 am to 5 pm
 Sunday Noon to 8 pm

Call and Talk to

- | | | | |
|-------|--------|--------|--------|
| Don | WBØVEZ | Blaine | WBØQLH |
| Denny | WØQR | Bob | WBØRQZ |
| Bill | WBØYHJ | Jim | KAØCRK |
| Joe | WAØWRI | | |



Communications Center
 443 N. 48th, Lincoln, Nebraska 68504

Kenwood — Yaesu — Drake — ICOM — Dentrion —
 Ten-Tec — Swan — Tempo — Midland — E.T.O. — Wilson

CALL TOLL FREE

I-800-2228-4097

Communications Center

443 N 48th Street
 Lincoln, Nebraska 68504
 In Nebraska Call (402)466-8402

Antenna Sale!

HY-GAIN

	Regular	Special
TH8DX	Super Thunderbird	18HT
TH3MK3	3 el. 10-15-20M beam	18AV7WB
TH3JR	3 el. 10-15-20M beam	80-10M Trap vertical
Hy-Quad	2 el. 10-15-20M Quid	40-10M Trap vertical
205BA	5 el. "Long John" 20M beam	12AVQ
155BA	5 el. "Long John" 15M beam	12AVQ
105BA	5 el. "Long John" 10M beam	14RMQ
204BA	4 el. 20M beam	58DQ
204MK5	5 el. conversion kit	80-10M Trap doublet
153BA	3 el. 15M beam	80-40M Trap doublet
103BA	3 el. 10M beam	6 el. 6M beam
402BA	2 el. 40M beam	8 el. 2M beam
BN 86	Balun for beam antennas	14 el. 2M beam
TH2MK3	2 el. 10-15-20M beam	Deluxe lightning arrestor

	Regular	Special
Classic 33	3 el. 10, 15, 20 Mtr. beam	304.75
Classic 36	6 el. 10, 15, 20 Mtr. beam	392.75
TA-33	3 el. 10, 15, 20 Mtr. beam	249.95
TA-36	6 el. 10, 15, 20 Mtr. beam	264.00
TA-33 Jr.	3 el. 10, 15, 20 Mtr. beam	392.75
TA-33 Jr.	3 el. 10, 15, 20 Mtr. beam	197.00
TA-40KR	40 Mtr. Add On	119.95

	Regular	Special
ATB-34	4 el. 10, 15, 20 Mtr. beam	A147-11
ATV-4	10, 15, 20, 40 Mtr. Vertical	11 ele. 146-148 Mhz. beam
ATV-5	10, 15, 20, 40, 80 Mtr. Vertical	A147-22
ARK-2	2 Mtr. Ringo Ranger	22 ele. Power Pack
ARK-6	6 Mtr. Ringo	A144-10
ARK-220	220 Mhz. Ringo Ranger	2 Mtr. "Twist" 10 ele.
ARK-450	435 Mhz. Ringo Ranger	A144-20
A144-11	11 ele. 144-146 Mhz. beam	2 Mtr. "Twist" 20 ele.

	Regular	Special
3-TBA	3 el. 10, 15, 20 Mtr. beam	189.95
4-BTV	10-40 Mtr. Vertical	109.95
5-BTV	10-80 Mtr. Vertical	139.95
RM-75	75 Meter Resonator	18.95
RM-75S	75 Meter Super Resonator	28.95
G6-144B	2 Mtr. Base Coilmeat	89.95
G7-144	2 Mtr. Base Coilmeat	139.95
G7-220	220 Mhz. Base Coilmeat	129.95

	Regular	Special
ATB-34	4 el. 10, 15, 20 Mtr. beam	289.95
ATV-4	10, 15, 20, 40 Mtr. Vertical	59.95
ATV-5	10, 15, 20, 40, 80 Mtr. Vertical	84.95
ARK-2	2 Mtr. Ringo Ranger	109.95
ARK-6	6 Mtr. Ringo	39.95
ARK-220	220 Mhz. Ringo Ranger	32.95
ARK-450	435 Mhz. Ringo Ranger	32.95
A144-11	11 ele. 144-146 Mhz. beam	32.95

HUSTLER
 3 el. 10, 15, 20 Mtr. beam 259.95
 10-40 Mtr. Vertical 109.95
 10-80 Mtr. Vertical 139.95
 75 Meter Resonator 18.95
 75 Meter Super Resonator 28.95
 2 Mtr. Base Coilmeat 89.95
 2 Mtr. Base Coilmeat 139.95
 220 Mhz. Base Coilmeat 129.95

ROTORS
 HAM 4 \$169.95 TZX Tailwater \$219.95
 Alliance HD73 \$109.95

Call for prices on rotor cable, Coax, Towers, and Accessories. All prices do not include shipping.



LOW-BUDGET POWER SUPPLIES

There are gems in the rough, waiting to be discovered and polished.

BY HANK OLSON, W6GXN

There was a time in recent electronics history when "power supply" meant: power transformer, 5Y3 tube, filter choke, and a couple of filter capacitors. As electronic circuitry grew in sophistication, voltage regulators were added, tubes were replaced by solid-state devices, and operating voltages (and power) were lowered. We now find ourselves at the point where a good, well-regulated, low-voltage supply is a necessity for operation of most solid-state circuits.

Modern voltage-regulator ICs have immensely simplified the job of regulation, just as other linear and digital ICs have made such regulation a requirement. Rugged silicon rectifier diodes are both inexpensive and available, and the physical size of an electrolytic capacitor of any given rating seems to go down about 25 per cent every five years.

The power transformer remains, however, almost unchanged over decades of

production. The old transformer-builder's formula which relates the power-handling capability of a transformer to its physical size is still valid. Further, the transformer, being a labor-intensive component, keeps rising in price, making the construction of power supplies an ever-more-expensive business. If you've recently consulted your copy of an Allied or Newark catalogue, I'm sure you've noticed that \$5 will not buy much in the way of a small (or any other size) power

transformer. The triad F-90X to F-94X series, my own choice for small, low-voltage supplies, is a good example of the high cost of power transformers: just over \$6 for the 35-mA unit, and up to \$12 for the 1-A unit. These Triad transformers are excellent units, providing great flexibility. I expect to continue using them in my work, but many experimenters simply can't afford them for hobby projects.

There are a number of ways to beat the high cost of power

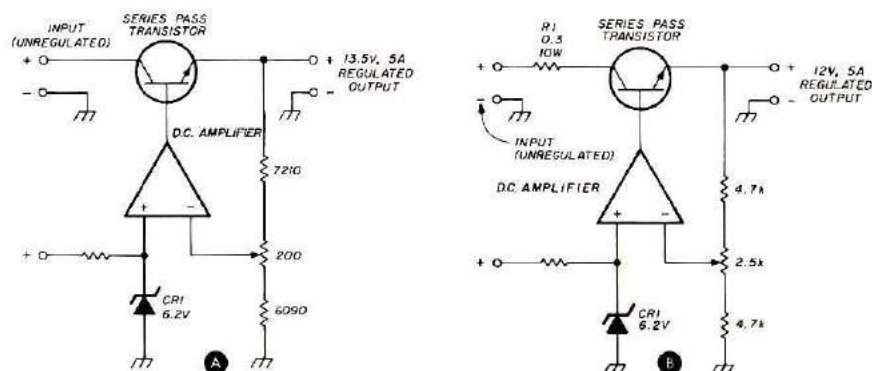

Fig. 1. A representative schematic diagram of the regulator portion of a surplus power supply (A), and the same supply after modification to provide a greater range of adjustment of the output voltage (B). R1 may not be needed; its purpose is to reduce the voltage drop across the series pass transistor, thus keeping it cooler.

supplies. One is to build your own, using transformers of the type that can be obtained from old stock which would not normally be considered. A second source of transformers is discarded consumer-electronic devices that are in the "replace-rather-than-repair" category. Complete supplies are often available, designed to odd-ball specifications. You can generally buy a complete surplus supply for low cost if it's designed for a nonstandard voltage output; that is, if it doesn't fit the usual requirements for modern solid-state circuits. The circuit of the odd-ball regulated supply can then be traced out, and changes made to make it put out a more useful voltage. There are many such packaged or modular supplies on the surplus market that were designed for some special purpose and have a "strange" output voltage, adjustable over very narrow limits. Generally, you can modify these supplies to put out voltages *lower* than they were designed for, because it's easier than to obtain a higher voltage. This usually means that more power will be dissipated in the supply, and part of your new design must account for getting rid of the excess heat. In almost every case, a few moments on the telephone to the manufacturer, ex-owner, or local representative, trying to obtain a circuit of the supply that you just bought surplus, will save hours of time. Even a circuit of a *similar* supply made by the same manufacturer is useful, as there are generally broad design philosophies in any one firm's engineering section. (In other words, it's usually easier and cheaper to slightly modify a working design than to start from scratch.) In making inquiries about such circuit diagrams, don't say that you're an experimenter or hobbyist trying to fix up a surplus junker. It's usually far more productive if you sound like a

growing young electronic business (with future potential for buying many power-supply modules).

When you obtain a nonstandard output-voltage supply, you can approach the problem with some general rules. There is generally a series-pass transistor (or several in parallel); these are mounted on some sort of heat sink, usually a finned alu-

minum extrusion. The circuit in Fig. 1A shows the general form of series-pass regulators. Note that the base of the series-pass transistor is driven by an amplifier which compares a fraction of the output voltage with a reference voltage (usually a zener diode). To change the output voltage, simply alter the resistor values in the output-voltage divider, as appropriate.

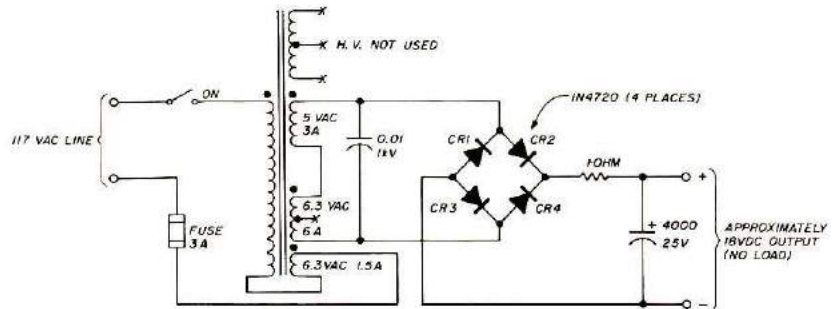

Fig. 2. You can use an old TV transformer to obtain low voltage for a dc supply. Tape the high-voltage leads and tie them out of the way. The bottom 6.3-volt winding is wired so as to boost the output of the other windings slightly — if wired backwards, it will reduce the output.

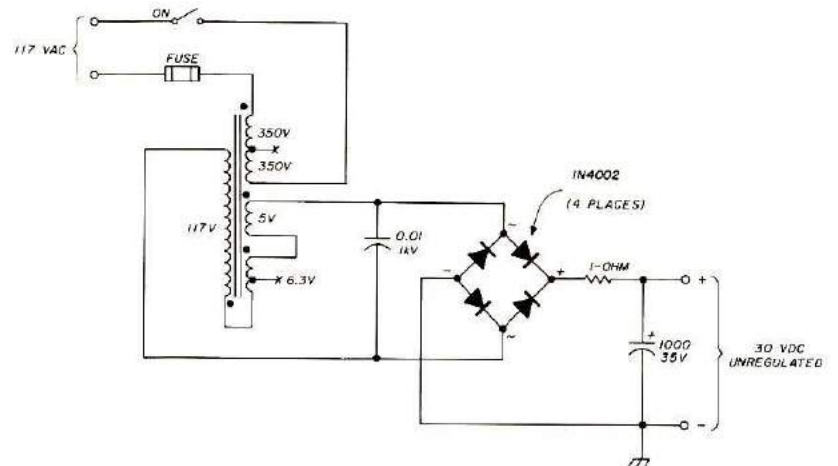

Fig. 3. The high-voltage winding of a power transformer can be fed from the ac line, thus making it work backwards. The former primary winding, hooked in series with the filament windings, will provide an unregulated output in the vicinity of 30 volts.

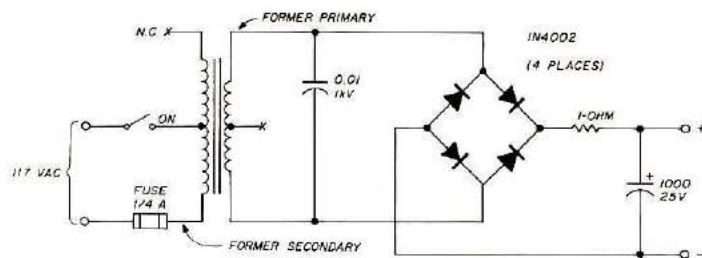

Fig. 4. An old vibrator power supply transformer from an auto radio will provide low voltage for many purposes. You may find some surplus vibrator supplies that were meant to work on 24 or 28 volts. These are good for low-voltage, high-current supplies too.

The original and modified circuits of a +13.5 volt regulated supply (as modified to produce +12 volts), are shown in Fig. 1. The original output-voltage-adjust control allowed the output to vary over only a few tenths of a volt. By modifying this voltage divider, we can now obtain greater output-voltage variation, as well as lower output voltage. Since the supply is built for 5-amperes output, this means that, after we've modified it for 12 volts,

You may encounter all sorts of regulated supplies, although the series-pass type is the most common. The other types will usually have a similar arrangement for comparing a fraction of the regulated output voltage with a reference voltage, and the modification can be done in a similar way.

Transformers

The use of transformers that were originally meant for heating the filaments of vacuum

filament transformers around, too. If you series connect the secondaries of a 6.3- and a 2.5-V filament transformer, you get 8.8 V, which is just about right for a 5-volt regulated supply. Since most tube rectifiers used a 5-volt filament, there are some 5-V filament transformers around, and, if you include transformers for transmitting-tube filaments, there are even some for 7.5 and 10 V. So, with a selection of 2.5, 5.0, 6.3, 7.5, and 10 V to choose from, it is easy to obtain a variety of voltages for any power supply. One item that was fairly common in the days of bridge rectifiers using 866 tube rectifiers was a single transformer with three 2.5-V secondaries. These three windings can be connected in series to yield a 7.5-V, 5-amp transformer.

Old power transformers from TV sets and radios can also be of use. The high-voltage secondary leads can be taped up and not used. The remaining 6.3 and 5-V secondaries can be series-connected for a low-voltage supply. The TV power transformer usually has a special 6.3-V, 1.5-amp winding with high-voltage insulation (for the damper tube), which can either be used in series with the other secondary windings or used in series with the primary to "boost" or "buck," and thereby increase or decrease the outputs of the other windings. This is shown in Fig. 2.

It is also possible to use the high-voltage winding of some power transformers as the 117-V primary. The former primary winding is then used as a low-voltage secondary. A typical TV power transformer might have a 700-volt (center-tapped) winding. If this 117/700 turns-ratio transformer is reversed and used as a step-down unit, you'll get about 20 volts from the winding that was formerly the input. If only half the 700-volt winding secondary is connected across the ac

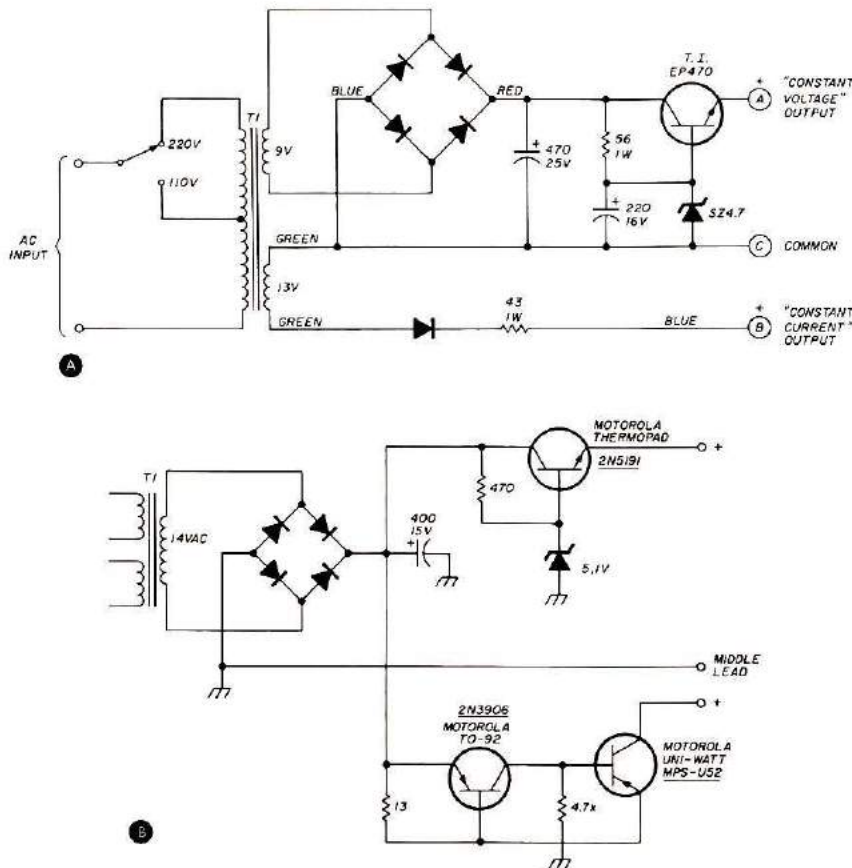

Fig. 5. Two supplies sometimes found in bargain bins were made for the Hewlett-Packard 35 calculators. The one at (A) is by CSA (03502A or LA21061), and that at (B) is an HP unit (82002A). The transistor numbers underlined are acceptable substitutes for the original components (which may not always be clearly marked).

the series-pass transistor(s) have to dissipate $(13.5 - 12.0) \times (5A) = 7.5 \text{ watts}$ more power at full load. If this presents a problem in over-heating the series-pass transistor(s), you can put in a series resistor, as shown, to reduce the excess heat being dissipated in this transistor.

tubes as a source of low voltage for semiconductor power supplies is well known. Since most vacuum tubes had 6.3-volt filaments (heaters), the 6.3-Vac filament transformer is the most common. However, there were many earlier tubes that used 2.5-V filaments, and so there are a fair number of 2.5-V

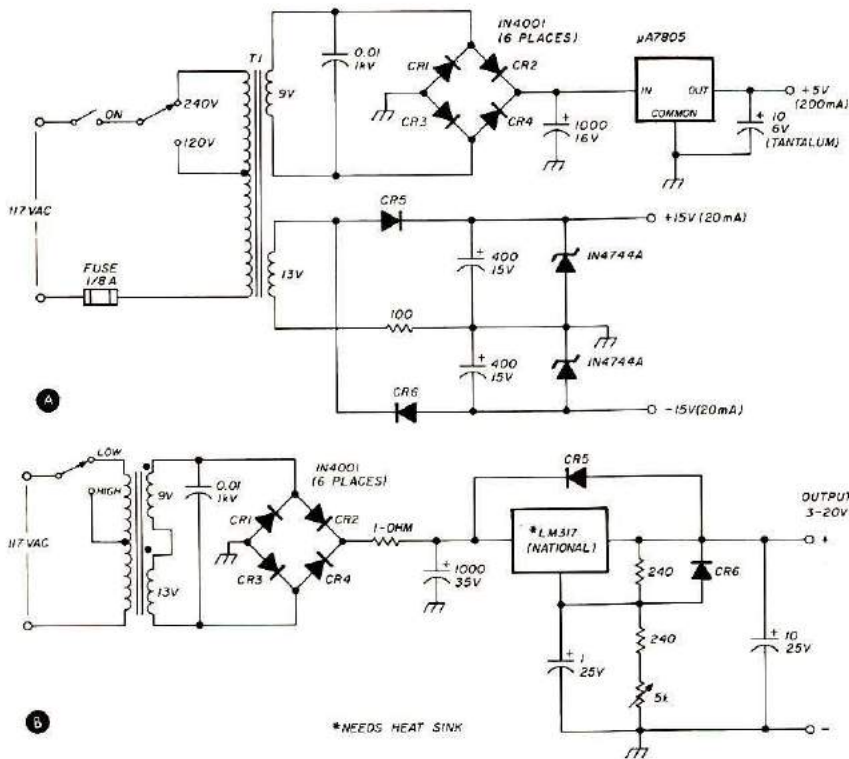

Fig. 6. You can turn the HP 03502A charger into a versatile supply by using the transformer with these components. The rectifiers from the original supply may be used, or the 1N4001s may be substituted. The three voltages put out by circuit (A) are commonly needed for logic and op-amp circuits. Another supply using the same transformer is shown at (B).

line, you'll get 40 volts output. The 5- and 6.3-volt windings will also produce proportionately less voltage, but they can be used in series with the 117-volt winding to increase or decrease its output voltage slightly. The backwards connection of a power transformer as described above is shown in Fig. 3.

How much power?

A general idea of how much power the transformer will produce can be obtained by summing the stated wattage of each winding. Take a Triad R11A as an example, and sum the secondary powers: $350\text{ V} \times .090\text{ A} = 31.5\text{ W}$; $5\text{ V} \times 3\text{ A} = 15\text{ W}$; and $6.3\text{ V} \times 3.5\text{ A} = 22.05\text{ W}$. The sum is 68 watts. Divide this by the new output voltage (say it is connected to give 20-volt output), and you get an output current of 3.4 amperes. However, since the former primary was wound

only 1/2 ampere, you can't really get the calculated 3.4-amp output, but at least 1/2 ampere can be drawn, and the transformer core will be far from its saturation limits. The whole idea behind using old filament or power transformers is to make a cheap

power supply — but it will be large; this is the main penalty paid in using older, "available" transformers.

Another source of low-voltage transformers that may be overlooked is the vibrator-supply transformers from older auto radios. Since the vibrators in these old radios operated at about 100 Hz and the tubes operated on +100 to +150 volts dc, you can operate such transformers "backwards" to obtain low voltages. Fig. 4 shows such a supply built around a 12-volt auto-radio transformer. There are also quite a few 24-volt vibrator transformers around, which will supply even higher (and generally more useful) voltages. The vibrator transformers for radios of the 6-volt category will, of course, be of less use.

Black boxes

There is another source of low-voltage transformers, available to those who are near "surplus" electronic stores. By surplus, I mean the sort of surplus that is written off by manufacturers as "excess," "nonrepairable," and so forth. Many of these surplus stores stock the little black plastic boxes which are chargers or ac power packs for electronic calculators and other small electronic devices. These little

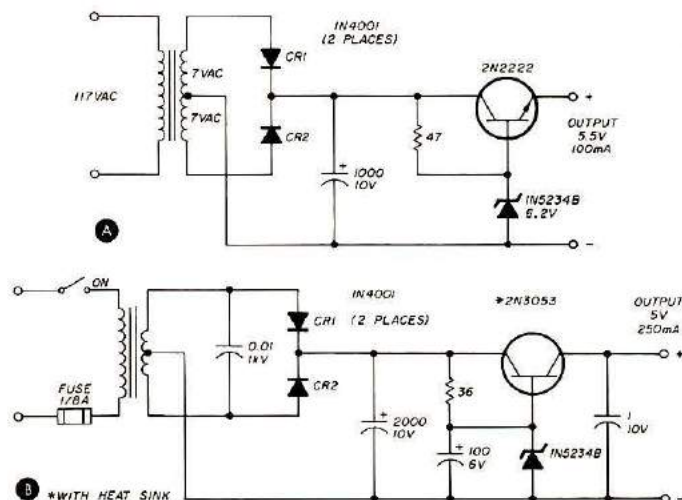

Fig. 7. A power supply by Atari, for their "Pong" games, is shown at (A). It can be modified into a more useful form for Amateur and experimenter needs as shown at (B).

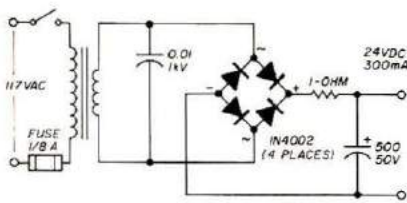

Fig. 8. A surplus supply, the "E.R. Products No. ER-443," can be turned into a good 24-volt, 300-mA supply. The output is unregulated; you can either feed it into a regulator circuit or use it for noncritical circuits such as lamps or small blower motors and relays.

black boxes usually contain a transformer, rectifier diodes, and sometimes transistors, zener-diodes, and filter capacitors. Unless they have been covered with a potting compound, the components can be removed and reused as power supply elements. Often, the only thing wrong with these little black boxes is a broken wire in the cord or plug which delivers low voltage to the device to be powered. Some idea of the power capability of the unit you select can be obtained from the name plate. For instance, a typical unit will be marked "5 watts" or perhaps "5 VA." If you then find that the transformer inside the black box has a 14-V secondary, you can expect $(5 VA \div 14 V) = 360 mA$ output current (assuming that the transformer efficiency is 100 per cent). Because of losses in the transformer (which are especially high in small, inexpensive transformers), you should generally figure on getting only about 50 per cent efficiency.

In my particular area (near a Hewlett-Packard plant), I found a large number of old charger modules for the original HP35 calculators. These fell into two categories: the older units made by CSA (type 03502A), and the newer units made by HP (type 82002A). The older unit is more difficult to take apart, and once apart it is seen to be a sort of haywired mass of components taped to the transformer plus a small circuit board beside it containing the

components of an emitter-follower regulator circuit. The original circuit diagrams of the two models (both are for the same calculator) are shown in **Fig. 5**. Whether you get the old or the new model, you'll have a transformer, one or two filter capacitors, one or three transistors, four or five silicon rectifier diodes, a five-volt zener diode, two or three resistors, and (in the older unit) a subminiature slide switch. This is a pretty fair "haul" for the \$2.50 to \$3.50 that old charger units sell for on the surplus market.

A couple of handy-dandy power supplies that have been built from the HP35 charger units parts are shown in **Fig. 6**. Note that standard part numbers have been used as alternates to some of the original parts, as you cannot be sure that all the parts in any particular unit will be good.

A visit to some local surplus stores revealed a number of available "black boxes" that were similar in price and appearance to the two HP35 calculator chargers. Another HP unit, the 82026A, is nothing more than a 10-V transformer; it is for later-model calculators like the HP21 and HP25. These later calculators have rectifier and regulator components in

the calculator proper. Also available were AC power supplies for Atari's "Pong" (a TV game), Litronix calculators, and several others which are apparently not for specific consumer units, being designated simply "AC Adapter, Model . . ." CSA seems to be a major manufacturer of these "black boxes," as their name appears on several varieties.

The original circuit of the Atari "Pong" unit is shown in **Fig. 7A**. It can be used as is for a +5 volt, 100-mA supply for logic ICs. If you happen to get one with a defective (open) 2N2222, as I did, you can saw the case open and rebuild the unit into an even better supply. **Fig. 7B** shows a +5 volt logic IC supply made from the "Pong" transformer, using the same rectifiers and zener diode; but with a new filter capacitor and transistor. The new supply has operated quite well at 250-mA output without overheating.

In **Fig. 8** is shown a simple 28-Vdc unregulated supply I made from a power supply module marked "Voycall," by ER Products (No. ER-443). This module contained only a transformer, and is perhaps representative of a whole class of small ac supplies for consumer

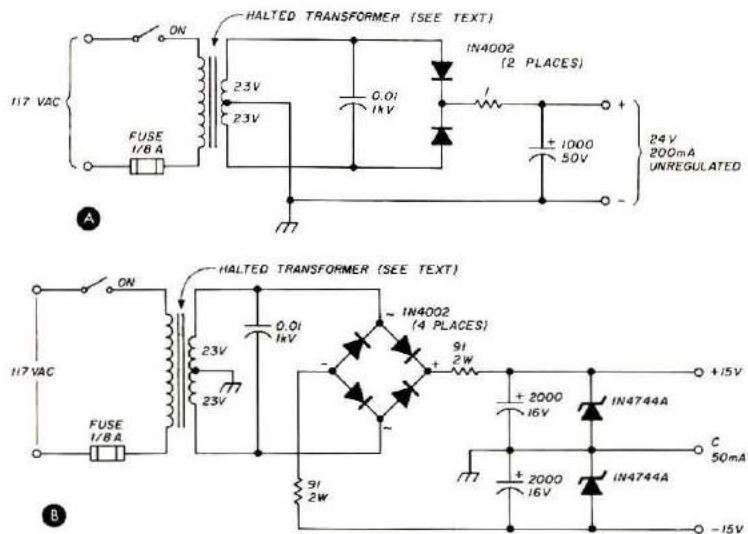

Fig. 9. A surplus transformer from Halted Electronics (729 E. Evelyn, Sunnyvale, California 94086) will make a couple of neat and useful supplies as shown in (A) and (B). The transformer designation is 56 001 668 7406, and it costs \$1, postpaid in the U.S.

electronics items. The unregulated supply made from it might be used for powering some small device like a cooling fan that runs on dc.

There are hundreds of small ac supply and charger modules, and I cannot explore them all here, nor present circuits developed from all their components. The circuits of **Figs. 5 through 8** give the general idea, however, and you can adapt your own units by using these examples. Some general rules: Don't accept modules where the plastic case (thermoplastic) is deformed, as they've been "cooked" and the transformer is probably defective. Don't accept modules that rattle, which means the transformer is loose inside and its fine wire leads are probably broken off right at the windings. If the wire leads are broken, dig a little bit into the nylon bobbin and see if enough wire can be exposed to solder onto. Also, check the wire leads to see if they have been "wetted" by solder when connections were made. These techniques will help you get the greatest number of useful transformers per dollar spent.

A Halted special

While shopping in one of the local surplus emporiums (Halted Electronics, 729 E. Evelyn, Sunnyvale, California 94086), I ran into a large quantity of little transformers which seem ideal for small supplies. These were priced at about 50 cents at the store, and the proprietor agreed that he could supply them for \$1 each postpaid in the continental U.S. **Fig. 9** shows two small supplies built from this bargain transformer.

The several techniques I've described here should allow a creative hobbyist to build a power supply at minimum cost. It requires more individual effort in testing, construction, and modification to build these supplies, but their unusually low prices should make it all worthwhile! **HRH**

Now, upgrade faster!

Here's 21 easy ways.

Satisfaction guaranteed or return in 10 days for full refund!

THEORY

Interview-style discussion of the Novice-class theory for beginners.
A two-tape set covering General theory with WØXI (set \$8.95).
New! Advanced theory covered in interviews with KØRW, an Extra-class.
New! Now study for your Extra exam with help from KØRW.

- Novice
- General
- Advanced
- Extra

Novice

An H. W. Sams book written in easy-to-understand style for beginners. \$3.95

General

Just published! Get the latest information for your FCC exam. \$6.50

BOOKS

MORSE CODE CASSETTES

Computer-generated to Morse specs in 7½, 10, 15 or 20 WPM (specify).
Simulated on-the-air contacts with simulated exams - 7½, 10, 13, 15 WPM.
Another hour of simulated contacts to bring you from 7½ WPM to 15 WPM with exam.
An hour of QSO-style contacts at 13 WPM with simulated exam for self-testing.
High-speed on-the-air contacts at 20, 23 and 26 WPM for Extra-class with simulated exam.
Another hour QXX, high-speed, contacts at 20, 23 and 26 WPM.
This super tape instructs "enhanced" code with wider spaces designed for beginners.
On-the-air-style copy generated to "enhanced" specifications with spacing for 7½ to 15 WPM.
Q-signals, short words and prosigns generated at 22, 33 and 40 WPM for recognition copy.
Randomly-generated characters, numbers and punctuation at 7½ to 10 WPM.
Random characters, numbers and punctuation at 13 and 15 WPM - no memorizing!

- Morse ^{WPM} _____
- QSO
- QSO 2
- QSO 13
- QXX
- QXX 2
- Super 5
- Super QSO
- Q-signals
- Random I
- Random II

Novice

Novice Combo includes manual and Super 5, QSO and Novice Theory tapes - \$14.95

General

General Combo includes manual, QSO-2 tape and 2-tape General Theory - \$19.95

Success

Success Kit includes oscillator, key, your choice of manual and two tapes - \$29.95

Speed

Speed Kit includes oscillator, key and your choice of Kantronics tape - \$20.95

COURSES

Yes, I want to upgrade faster!

ORDERS

Name _____
Address _____
City _____ State _____ Zip _____
 Master Charge Visa Check
Card no. _____
Signature _____ Expiration date _____

Please include \$1 shipping/handling for each tape and \$2 for combination orders.

tapes

\$4.95 each

Kantronics

1202 E. 23rd Street (913) 842-7745
Lawrence, Kansas 66044

the Ultimate 1:1 BALUN

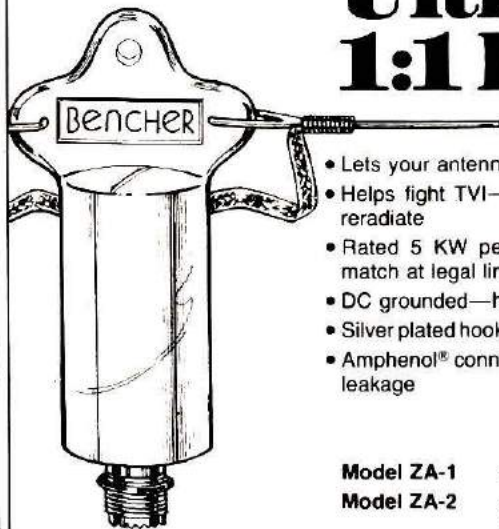

- Lets your antenna radiate—not your coax
- Helps fight TVI—no ferrite core to saturate or reradiate
- Rated 5 KW peak—accepts substantial mismatch at legal limit
- DC grounded—helps protect against lightning
- Silver plated hook-up braid; Custom molded case
- Amphenol® connector; Rubber ring to stop water leakage

Model ZA-1	3.5-30 mHz	\$15.95
Model ZA-2	optimized 14-30 mHz includes hardware for 2" boom	\$17.95

Available at selected
dealers, add \$2.00
postage and handling
in U.S.A.
WRITE FOR LITERATURE

BENCHER, INC.

333 West Lake Street, Dept A
Chicago, Illinois 60606 (312) 263-1808

TOWERS

by ALUMA

HIGHEST QUALITY
ALUMINUM & STEEL

60 Ft. Aluminum,
Crank-Up
Model T-60-H

40' Steel
Crank-Up
Model SHD-40

- ★ TELESCOPING
(CRANK UP)
- ★ GUYED (STACK-UP)
- ★ TILT-OVER MODELS

Easy to install. Low Prices.
Crank-ups to 100 ft.

EXCELLENT FOR
HAM COMMUNICATIONS

SPECIAL
Four Section 50 Ft.
Van Mounted Crank-Up
Aluma Tower

Over 36 types aluminum
and steel towers made—
specials designed and
made—write for details

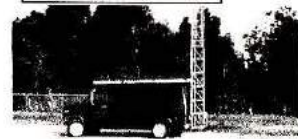

ALUMA TOWER CO.
Box 2806 HH
VERO BEACH, FLA. 32960
PHONE (305) 567-3423
TELEX 80-3405

Call or Write for Delivery or Quote

KENWOOD TS-120S



**MADISON
ELECTRONICS SUPPLY, INC.**

1508 MCKINNEY • HOUSTON, TEXAS 77002
713/658-0268

LEAVE A MESSAGE & WE'LL CALL YOU BACK!

ANTENNAS

**THE RADIO AMATEUR ANTENNA
HANDBOOK** by William I. Orr, W6SAI and
Stuart Cowan, W2LX

If you are pondering what new antennas to put up, we recommend you read this very popular book. It contains lots of well illustrated construction projects for vertical, long wire, and HF/VHF beam antennas. But, you'll also get information not usually found in antenna books. There is an honest judgment of antenna gain figures, information on the best and worst antenna locations and heights, a long look at the quad vs. the yagi antenna, information on baluns and how to use them, and some new information on the increasingly popular Sloper and Delta Loop antennas. The text is based on proven data plus practical, on-the-air experience. We don't expect you'll agree with everything Orr and Cowan have to say, but we are convinced that **The Radio Amateur Antenna Handbook** will make a valuable and often consulted addition to any Ham's library. 190 pages. ©1978.

□RP-AH

Softbound \$6.95

SIMPLE LOW-COST WIRE ANTENNAS

Learn how to build simple, economical wire antennas. Even if you don't know a feedline from a feed-through, W6SAI will get you on the air with an effective low-cost wire antenna. And, apartment dwellers take note! Fool your landlord and your neighbors with some of the "invisible" antennas found here. For the old-timer as well as the beginner, it's a clearly written, well diagrammed, and even humorous antenna book. 192 pages. ©1972.

□RP-WA

Softbound \$5.95

Two exciting antenna books from Ham Radio's Bookstore.
Call or write today.

Please add \$1.00 to cover shipping and handling.

HAM RADIO'S BOOKSTORE

GREENVILLE, N. H. 03048

CALL TOLL FREE 1 (800) 258-5353

Multi- purpose Multi- meter

Some not-so-obvious uses for your primary test instrument

BY JOHN EDWARDS, WB2IBE

"I wish I had a field-strength meter, so I could tell how my signal is getting out." "How much life is still in the batteries in that handheld?" "Is that transistor NPN or PNP?"

Have you ever asked these questions, either aloud or under your breath? And then wondered what to do about answering them? The answer may well be sitting right in your shack, repair bench, or, at the least, in a nearby dealer's store or catalogue. This miracle instrument is none other than the lowly multimeter — the volt/ohm/milliammeter, sometimes called VOM for short.

You thought the instrument was needed only by those who are eager to dive into their rigs, tracking down a trouble to the last open resistor or shorted capacitor? And you quake in your socks at the thought of doing the same when your favorite piece of gear develops that ailing feeling? There's no need to feel overwhelmed by such prospects at all — armed with a schematic diagram (especially one that lists the normal voltages for your set), the theory you studied for your

Amateur exam, and a little planning, you would be surprised how many seemingly big troubles turn out to be a defective component, easily replaced. But, then, that's not what this article is about; the *obvious* use for a VOM is to check volts, ohms, and milliamperes (or amperes). I'm going to give you a glimpse of some not-so-obvious uses for your multimeter. If you catch the idea, you'll think of several others as you read.

Operation and appearance

The VOM's most noticeable feature is its meter. Upon close examination, you'll see that the meter's face is marked with four or five different scales. Each scale represents a different type of measurement — AC, DC, OHMS, dB, and possibly a BATTERY CHECK range used for testing the VOM's internal battery (needed for resistance measurements).

Below the meter is a large knob usually called the RANGE SWITCH. The switch first selects various functions — AC and DC VOLTS for electrical potential tests; OHMS for resistance checks, and DC AMPS (or

milliamperes) for current readings. Beyond that, each setting is broken into various *ranges* for more accurate readings. The number of ranges depends on the sophistication — and the cost — of the VOM.

The VOM's other major feature is its probe, the device that's physically applied to a circuit to take readings. The probe usually comes in two types; a pencil-shaped positive lead and an alligator clip used as a ground. Besides the all-purpose probe that comes with the VOM, some manufacturers also offer an optional rf probe, used to detect and measure high-frequency energy. Since the rf probe is widely used in a number of transmitter adjustments, you'll probably find dozens of uses for one in your shack. More on the rf probe later.

Types of VOMs

VOMs come in two basic forms: the regular type and the fet (field-effect transistor) variety. Why two types? Well, the regular VOM has one big disadvantage — a low internal resistance. When measuring many high-resistance circuits,

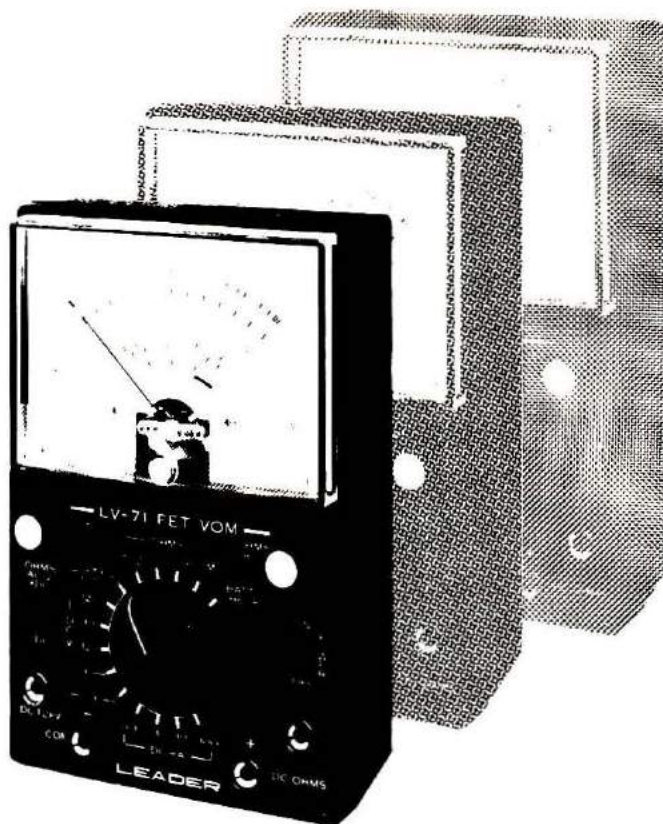

the regular VOM has a nasty habit of actually loading down the circuit it's testing. Since the VOM is then causing current flow not normally found in the circuit under actual operating conditions, the result is a somewhat inaccurate reading. The fet VOM sidesteps this problem by containing a small amplifier, which prevents the meter from drawing current. So, if you're going to use a VOM to troubleshoot a sensitive or complex circuit — you'll need an fet type. A regular VOM, by the way, works just fine for component tests and many other common uses.

How they're used

Now that you have an idea of the layout and types of VOMs, it's time to take a look at some samples of VOM uses especially suited for common measurements around the shack. While these aren't the only tests you can make with a VOM — all of the applications could easily fill a book — it should give you an idea of the instrument's versatility.

Battery testing

Most of us, at one time or another, run into battery problems. If you own a portable or hand-held rig, you constantly worry about just how much power your batteries will deliver before needing a charge. Unfortunately, many hams don't know how to properly test batteries.

The most logical way to check the voltage would be by touching the appropriate VOM leads to either end of the cell; the reading that shows up on the meter should be the voltage being generated. But, things don't always work that way. A true voltage test can only be made when a cell is operating under load. A battery can be on its last legs but still show a reasonable voltage when it is tested out of a circuit. The only way to get an idea of a battery's true condition is to test it while it's actually operating.

Multipurpose



With the flick of a switch, this VOM can double its voltage range, which provides higher accuracy at the upper end of the scale (photo courtesy Radio Shack).

An inexpensive, but highly effective, VOM that will fit in your pocket or tool kit. No range switch is needed because you can select the function and range by plugging the probe leads into the appropriate jacks (photo courtesy Radio Shack).



Test meters can range from the most simple and lightweight to the modern, digital-readout instrument featuring extreme accuracy and ease of reading.

e Multimeter



This pocket-sized VOM has a range switch, and boasts fet circuitry as well (photo courtesy Leader Instrument Corp.).

An fet VOM fit for a test bench or your ham shack. Modern fet circuitry provides higher input impedance and greater resistance-measuring range (photo courtesy Radio Shack).

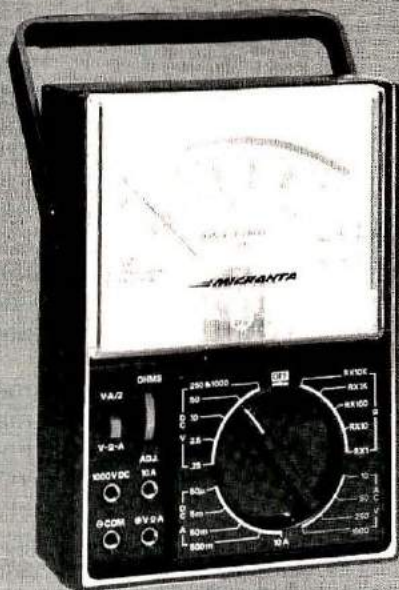

Advanced technology catches up with the VOM — push-button selectors, digital readout, light weight, portability and sleek styling make this the instrument of the future (photo courtesy Hewlett-Packard).

To do this, keep the battery in its holder (Fig. 1) and place the correct VOM leads at either end of a cell. Next, switch on the handheld (or other battery-operated device) and observe the reading on the VOM's meter in the DC VOLTS setting. This reading shows the actual voltage being delivered under loaded conditions. If you see that one cell isn't working as well as the others, it should be replaced or removed and recharged separately.

Transistor testing

There are few experiences more frustrating than discovering that the project you just built won't work. Often, the harried builder will pull apart circuit board after circuit board in search of the problem, only to discover that the fault was in a defective transistor.

Another annoying problem is the unmarked, surplus transistor. In these days of rising prices and unwillingness on the part of manufacturers to sell parts in small quantities, hams must necessarily turn to purchasing odd-lot and bargain-basement transistors. While prices for these components are low, the buyer can often be confused by unlabeled and mislabeled parts. Luckily, for determining quality and deciphering unmarked transistors, the VOM is a lifesaver.

For instance, an easy way to check for a defective power transistor is to follow the directions in Fig. 2. Merely place the probe leads on the terminals indicated, and use your VOM (in the OHMS mode) to check for a high- or low-resistance reading. Don't worry about the actual measurement you get, since the spread between high and low resistance in this test is so outstanding that you'll easily notice the difference. If your readings differ in any way from those of the diagram, there's probably something wrong with the transistor and it should be discarded.

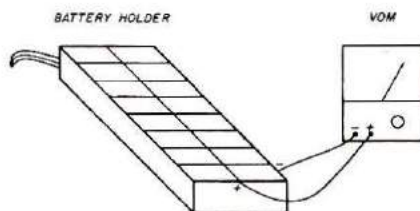

Fig. 1. Battery voltage should be checked under normal load conditions. Measure the voltage across each cell while the receiver, or other device, is turned on.

Another transistor check you can make with your VOM is to identify and sort bipolar PNP and NPN transistors. To do this, apply the VOM's probe leads to two terminals at a time. One terminal pair will show a high resistance in either direction; these are the emitter and collector terminals. Next, place the negative VOM lead on the base terminal and apply the positive lead to either of the remaining unidentified terminals. If you get a low-resistance reading, the transistor is a PNP type, otherwise it's an NPN.

The final transistor test is separating the emitter and collector terminals. For this, place the positive and negative probe leads on each of the two unidentified transistor terminals. Follow this by taking resistance readings in both directions. If the transistor is a PNP type, you will obtain a lower resistance reading with the negative probe on the collector and the positive probe on the emitter than you will the other way around. For an NPN transistor, the exact opposite is true.

Field-strength measurements

While a power meter does an excellent job of telling you how much rf your transmitter is delivering to the antenna, how can you tell in what direction your antenna is radiating the power? If you have a brand-new beam and find that you're getting better reports off of its back than the front, you know that you have a serious problem. But, since your power

meter is connected to your coax, how can you check the power levels outside of your antenna? With a field strength meter, that's how!

With a little bit of adaptation, your VOM can be converted into a top-notch field-strength meter. However, before you can take any measurements, you'll have to make two changes to your VOM. First, its regular probe must be replaced with the rf probe mentioned earlier. The reason for this is that you'll be using the VOM to detect rf, not regular dc or 60-Hz ac voltage. The rf probe should cost you about \$10 new, or you can make your own from some spare parts, as shown in Fig. 3.

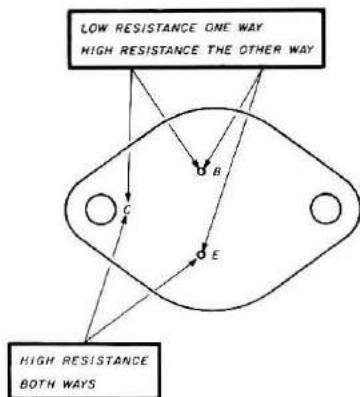

Fig. 2. You can check transistors by knowing where to connect the VOM probes. Measure resistance from collector to base, then reverse the probes; there should be a large difference in the readings. The same is true for resistance between base and emitter. Emitter-to-collector resistance should be high with the probes in either direction.

The other thing you must do to convert your VOM into a field strength meter is to add about four inches of scrap wire to the rf probe's tip. The wire will act as an antenna. After you do that, switch your VOM to its lowest DC VOLTS setting, and you're ready for business.

Now, back to the malfunctioning beam. By taking your VOM to the antenna site, you can walk around the antenna and check its radiated power from different angles (Fig. 4).

By making minor adjustments to the antenna's element spacing and checking the results with your VOM, you can check and correct the beam's directivity. While antenna models are tested at the factory for performance, changes can occur, and they can be improperly assembled, so it's a good idea to test all your antennas in advance, before going through the trouble of mounting them. Obviously, if you're building your own antenna, a field-strength test is a must. This test works well with wire dipoles, too.

The VOM as an S-Meter

While we're on the subject of signal measurements, let's take a look at the receiving end of the picture. Yes, the VOM can also act as an S-meter. You may not have given the matter much thought, but some receivers don't come with S-meters. For instance, most older 2-meter rigs, especially of the surplus variety, don't have them. QRP transceivers usually sacrifice an S-meter for space and power considerations.

To use your VOM as an S-meter, consult your rig's schematic diagram and find the AVC line (Fig. 5). By touching one VOM probe lead to the line and attaching the other lead to a ground, the VOM will read the AGC voltage and act as a very sensitive indicator of received signal strength. Note: some AGC lines have a positive voltage, some have negative. Hook your meter up accordingly.

Hot or cold?

How about using your VOM as a thermometer? There are

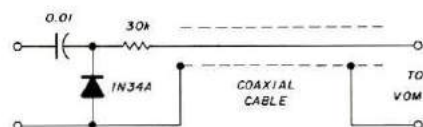

Fig. 3. Make an rf probe for your VOM, and it can be used to look for rf energy anywhere, especially on transmission lines and radiated from your antenna.

DSI HAS DONE IT AGAIN

QUIK-KIT II®

INCLUDES PROPORTIONAL OVEN TIME BASE



MODEL 5600A KIT

WHY BUY A 5600A? Because 95% of the assembly is completed by DSI and you are only one hour away from solving all those difficult bench problems. From setting the frequency of a radio signal to within 1/10 of a Hz, to checking the frequency of a 400 MHz mobile radio. Whether you are servicing a VTR, trouble shooting a PCL circuit, the 5600A is the right counter with accuracy that will meet any FCC (and mobile, broadcast, or telecommunication) requirements. On the bench or in the field the 5600A will do the job you need. The 5600A includes a self-contained battery holder providing instant portability or we offer a 10 hour rechargeable battery pack option. Other options include a audio multiplier which allows you to resolve a 1/1000 of a Hz signal and finally a 25db preamplifier with an adjustable attenuator making the 5600A perfect for communications, TV servicing, industrial testing or meeting your QSO on the correct frequency every time.

FACTS ARE FACTS. With the introduction of the 5600A, the industry set on the competition. This may sound like a bold statement on the part of DSI, BUT FACTS ARE FACTS. No counter manufacturer except DSI offers a Full Range 50 MHz to 600 MHz counter with — 9 Digits — 0.1 Hz resolution — 2 PPM 10° to 40° C proportional oven — RF pre-amp — 600 MHz prescaler — three selectable gate times — oven ready, standby and gate time indicator lights as standard features — For only \$149.95 kit and \$179.95 factory wired. In fact the competition doesn't even come close unless you consider \$200.00 to \$800.00 close. With DSI having the best price to quality features ratio in the industry, no wonder we've become one of the world's largest manufacturers of high quality frequency counter instrumentation.

**FOR INFORMATION — DEALER LOCATION — ORDERS — OEM
CALL 800-854-2049 CALIFORNIA RESIDENTS CALL 800-542-6253**

Model	Price	Frequency Range	Accuracy Over Temperature	Sensitivity			Number of Front Panel	Size of Transistor	Power Requirements	Size (H x W x D)
				100 Hz - 10 MHz	30 - 250 MHz	100 - 1000 MHz				
5600A-K	\$149.95	50 Hz - 600 MHz	Proportional Oven 2 PPM 10° - 40° C	10 MV	10 MV	50 MV	9	4 Inch	115 VAC or 8.2-14.5 VDC	9" x 9" x 5"
4950	99.95	50 Hz - 550 MHz	TCXO 1 PPM 17° - 40° C	25 MV	25 MV	75 MV	8	5 Inch	115 VAC or 8.2-14.5 VDC	2" x 8" x 5"
5001-P4	\$149.95	50 Hz - 350 MHz	TCXO 1 PPM 17° - 40° C	25 MV	20 MV	75 MV	3	4 Inch	115 VAC or 8.2-14.5 VDC or NICAD BAK	1" x 3 1/2" x 5 1/2"

5600A wired factory burned in 1 year limited warranty. 5600A kit 90 day limited warranty. Price and/or specifications subject to change without notice or obligation.

*With AC Kit Adaptor



3550 OWNERS
You can add the
35P.2 .22 PPM
10° to 40° C
proportional oven
to your
existing 3550

T101 Ant. \$3.95
AC-9 AC Adaptor 7.95
35P.2 29.95
Factory Installed 49.95



DSI INSTRUMENTS, INC.
7924 Ronson Road
San Diego, California 92111

TERMS: MC - VISA - AE - Check - M.O. - COD in U.S. Funds.
Please add 10% to a maximum of \$19.00 for shipping, handling
and insurance. Orders outside of USA & Canada, please add
\$20.00 additional to cover air shipment. California residents add
6% Sales Tax.

5600A Kit \$149.95
5600A Wired 179.95
AC-9 AC Adaptor 7.95
T600 BNC Ant. 7.95

BUILT-IN OPTIONS

BA56 Rechargeable
10 Hr. Bat. Pack 24.95
AM56 Audio Multiplier
.001Hz Resolution 34.95
PA56 25dB Preamplifier
with Attenuator 59.95

temperature probes made specifically for that purpose, but it's even easier to do than that. Most diodes are temperature sensitive, especially when they are reverse biased (voltage applied opposite to the normal polarity). If you set your VOM to read ohms, connect the probes across a diode, and warm it (or cool it), you'll note the reading change. Try several diodes, both silicon and germanium, and find the one that provides the greatest change in reading. Make up a chart that tells you how many ohms relate to what temperature, and presto!, you have a remote-indicating thermometer. In addition to comparing outdoor temperature with indoor temperature, you can use it for looking at the temperature of the exhaust air coming out of your final amplifier. Or, put it into a small plastic tube (sealed, and filled with silicone grease) to immerse in your etching bath when you make printed circuit boards. Oh, yes, the diode is sensitive to rf fields, so don't use it inside your transmitter, and you'd better hang a 0.01- μ F disk ceramic capacitor across it, just to be sure.

Advanced Meters

So there you have it — a selection of handy uses for a most handy meter. But, before I wrap things up, you should know about some recent advances in the VOM field.

Undoubtedly, you've heard about the new digital multi-

meters. Instead of using a conventional meter, like the VOM, they employ LEDs to flash a numeric display. In some quarters, it has been rumored that digital multimeters will soon replace VOMs in the same way that digital watches are replacing dial-and-hand jobs. Actually, nothing could be further from the truth; regular watches are still around, and VOMs will also continue to flourish. While digital multimeters have some advantages, they also have a number of inherent drawbacks. For instance, consider that it takes power to run those flashy digits. If you want to use your meter, say, for an outdoor field-strength test, you're going to

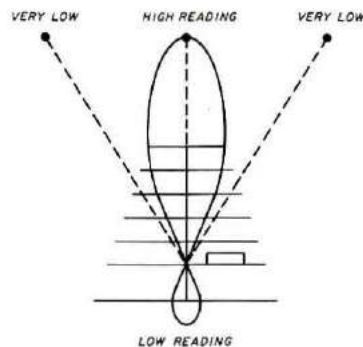

Fig. 4. Check the radiation pattern from your beam antenna by moving the rf probe and VOM around in the radiated field.

have a hard time finding an outlet at your antenna site, unless you have a battery-operated model. Cost can be another problem, with even simple digital multimeters far

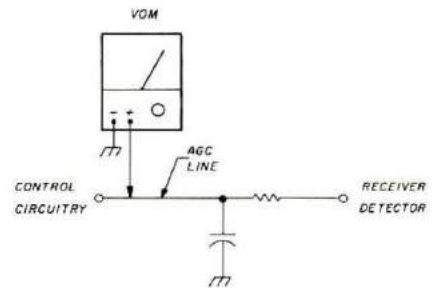

Fig. 5. Your VOM will work as a substitute S-meter. Just monitor the voltage on the receiver's agc line. Note that this one is set to read a positive voltage; some receivers have a negative agc voltage, so you'll have to reverse the probes to get a correct reading.

outstripping the price of a VOM. Other factors in the VOM's favor are its simplicity (fewer parts to break), and the VOM's generally smaller size. These are all points you'll want to consider when it comes time for you to make your meter purchase.

However, if you're like most hams, you'll probably agree with my television-addicted friend. How does he spell relief? V-O-M, of course. It's one piece of test equipment that'll prevent lots of headaches.

For more information

DSI Instruments, Inc., 7924 Ronson Road, San Diego, California 92111

Heath Company (Heathkit), Benton Harbor, Michigan 49022

Leader Instruments Corp., 151 Dupont Street, Plainview, New York 11803

Radio Shack, One Tandy Center, Fort Worth, Texas 76102.

Table 1. Some popular VOMs and prices.

Company	Model	Cost	FET?	Notes
DSI Instruments	YF-370	\$ 29.95	N	
Heathkit	IM-105	\$ 89.95	N	Kit, \$100 assembled
Heathkit	IM-1104	\$109.95	Y	Kit, \$195 assembled
Leader	LV-71	—	Y	
Leader	LT-70B	—	N	
Radio Shack	22-027	\$ 8.95	N	Pocket-sized
Radio Shack	22-201	\$ 16.95	N	
Radio Shack	22-202	\$ 22.95	N	
Radio Shack	22-203	\$ 29.95	N	
Radio Shack	22-204	\$ 34.95	N	
Radio Shack	22-207	\$ 49.95	N	
Radio Shack	22-208	\$ 59.95	Y	

HRH

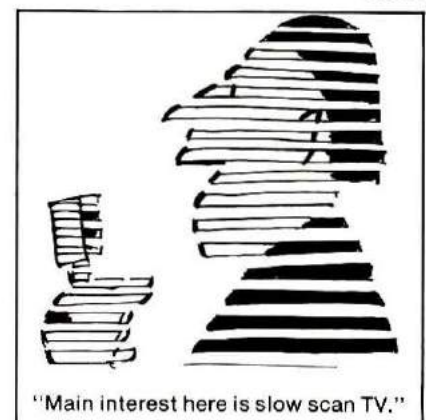

1980

Radio Amateur Callbook



Don't be one of those who waits until the year is half over to buy a new callbook. Invest in a callbook today and get a full year's use out of your purchase. Crammed full of the latest addresses and QSL information.

You'll find:

Boldface calls, names and addresses for every licensed Amateur in the U.S.

CB-US Softbound \$16.95



The Foreign Callbook

DXing is a real joy, but it's even better when you get back QSL cards from the countries you've worked. The most important tool in getting those cards is to have a copy of the 1980 Foreign Callbook on your operating table. Stations are listed by country, call, name and address in bold, easy-to-read type. CB-F Softbound \$15.95
Please include \$1.75 additional shipping for each Callbook ordered.

HAM RADIO'S BOOKSTORE

GREENVILLE, N. H. 03048

(800) 258-5353

1980
1980
HANDBOOK
See page 42 for super value
on 1980 ARRL Handbook.
1980

More details? Ad Check page 78.

Loop Antenna

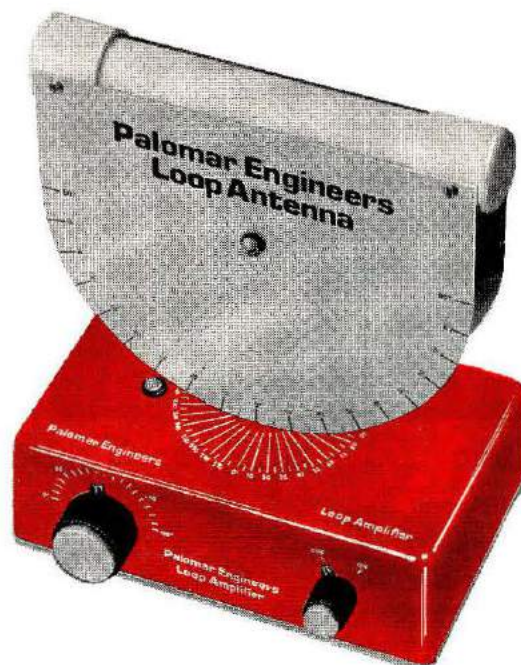

Here is an exciting new device to improve your reception on 160, 80, the broadcast band, and on VLF.

It is well known that loops pick up far less noise than most other antennas. And they can null out interference. Now Palomar Engineers brings you these features and more in a compact, carefully engineered, attractive desktop package.

Unlike ordinary direction-finder loops, it tilts to match the incoming wave front. The result: Deep nulls up to 70 db. You have to listen to believe it!

Does the Loran on 160 give you a headache? The loop practically eliminates it. Broadcast station 2nd harmonic ruining your DX? Turn and tilt the loop and it's gone. Does your friend in the next block with his kilowatt block those weak ones? Use the loop and hear him fade out.

Loop nulls are very sharp on local and ground wave signals but usually are broad or nonexistent on distant skywave signals. This allows local interference to be eliminated while DX stations can still be heard from all directions.

The loops are Litz-wire wound on RF ferrite rods. They plug into the Loop Amplifier which boosts the loop signal 20 db and isolates and preserves the high Q of the loop. The tuning control peaks the loop and gives extra preselection to your receiver.

Plug-in loops are available for these bands:

- 150-550 KHz (VLF)
- 540-1600 KHz (Broadcast)
- 1600-5000 KHz (160 & 80 meters)
- 10-40 KHz (Omega)
- 40-150 KHz (WWVB, Loran)



Send for free descriptive brochure.

Loop Amplifier \$67.50; Plug-in Loop Antennas \$47.50 each [specify frequency band]. To order add \$3 packing/shipping. Calif. residents add sales tax.

Palomar Engineers

Box 455, Escondido, CA. 92025 • Phone: [714] 747-3343

By Dave Heil, K8MN

A LAZY VERTICAL For Top Band

A Laid-Back Antenna For Restricted Space

When I moved from a 12-acre antenna farm to a city-sized lot, one of the first thoughts that came to my mind was about how I could erect an antenna for 160 meters. I began devoting much of my spare time to reading books and articles on the topic of top-band skywires.* Anything approaching a full-sized radiator was definitely out, as there was quite simply no room in the yard. After much thought, the choice was narrowed to two types of antennas — the inverted "L," and the vertical.

There were drawbacks to both types. The inverted L needed two fairly high supports: I had only one; my sixty-foot aluminum tower with

a triband Yagi perched atop it. However, the matching system for such an effort is not simple to build or adjust. While a full quarter-wave, or even one-eighth-wave, vertical could have been put up, this was judged impractical because of the need for guy wires. Besides, I'm generally tight-fisted, and I didn't want to spend money for materials for such a system.

I began brainstorming with WB8LUA to come up with an idea for an effective antenna that could be constructed, using materials that were already on hand in the junk box (actually, junk room). What we finally decided upon is referred to as the lazy vertical.

The antenna is basically a wire radiator running diagonally from the top of my tower to a piece of 2 × 3 lumber protruding a few feet out of the ground. The radiator is base-loaded to achieve quarter-wave resonance (see Fig. 1).

Construction of the antenna could not be much easier. The first step is to find a spot for the 2 × 3 post, keeping in mind that you will want to use as much wire as possible. I used a post-hole digger to plant the wood about two feet into the ground, then poured some concrete to firm it up. This is not really necessary; since there will be little strain on the support, tamping earth around the post will probably suffice. You should give the wood a couple of coats of paint to protect it from the elements and make it look a bit nicer. The next step is to attach a small screw-eye near the top of the post, then fasten an egg insulator to it with a short length of wire. Then, using two cone type standoff insulators, mount a suitable piece of coil stock to the side of the post. I used Barker and Williamson No. 3064, which is three inches in diameter and has a total

*Top band is the common name given to the Amateur 160-meter band, dating from the earlier use of wavelength to describe the part of the spectrum, rather than megahertz as is common today.

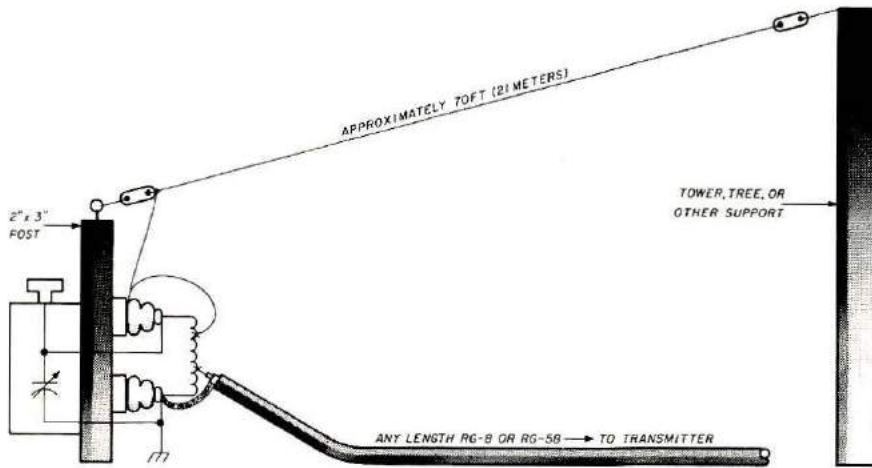

Fig. 1. The lazy vertical is simply a wire with a loading/matching coil at the bottom. The length is not overly critical, and you can use almost any support that is available — the closer to vertical you can get the wire, the better. The capacitor across the coil should be protected from the weather by some means. A radial system helps the antenna, and anything from a few ground rods to several buried radial wires will do.

inductance of about $32 \mu\text{H}$. If you don't plan to use at least 70-75 feet of wire for the radiator, then use more inductance; I barely had enough. Next, add a 100 pF variable capacitor (the wider the spacing the better) in parallel with the loading coil. I mounted mine in a Bud Minibox for ease in assembly and protection from weather. If this is done, you'll need a ceramic feedthrough insulator for the Minibox.

Now, you're ready for the wire. Use any gauge that happens to be convenient. I used No. 16 AWG (1.3 mm) because it is not as conspicuous, and because I had some. Run the wire from the top of the highest support you have available down to the post and through the eye of the egg insulator. Terminate it at the top of the loading coil. Ground the other end of the coil.

Although this antenna will work with only one or two driven ground rods, performance can be dramatically improved with the addition of a radial system. I installed ten radials of No. 8 AWG (3.3 mm) aluminum buried just below the

surface of the ground, and I plan to add about ten more in the near future.

Matching the system was accomplished in a short time by using trial and error, since neither a grid-dip oscillator nor an antenna noise-bridge were available. The braid of the RG8/U feedline was grounded, and the center conductor was tapped up from the bottom of the coil a turn at a time, until a dip in SWR was observed. In my case, the tap worked best five turns up from the bottom. Then, I tapped down from the radiator to the top of the coil until resonance was indicated. I might add that at this point, approximately two turns down from the top of the inductor, the lowest SWR observed was 2:1. No amount of readjustment would bring the reflected power down. It was then that I shunted the variable capacitor across the coil. After experimenting with various settings of the capacitor, I achieved a 1.2:1 match at 1825 kHz.

Normally, one would expect an antenna of this type to have a very narrow bandwidth, but I found that the SWR was only

1.6:1 at 1800 and 1850 kHz, enabling me to operate anywhere in the most heavily populated areas of the band (see Fig. 2). I'm not sure, but I surmise that the tower and triband Yagi have some effect on bandwidth.

Results from use of this antenna have amazed me. The lazy vertical easily outperforms my old half-wave dipole (which was, admittedly, quite low). Daylight QSOs of up to 75 miles with S-8 signals have been accomplished. Despite quite noisy conditions during the month of May, evening QSOs with New York, Pennsylvania, New Hampshire, Michigan, Massachusetts, and Georgia have all paid off with signal reports of no less than S-8, and often S-9 and above. My equipment is a Yaesu FT-101E.

I take great delight in the fact that this antenna performs so well and cost so little. The only components I purchased were the Minibox at \$3.50, and the inductor at \$7.50. Even if everything must be purchased new, the total cash outlay

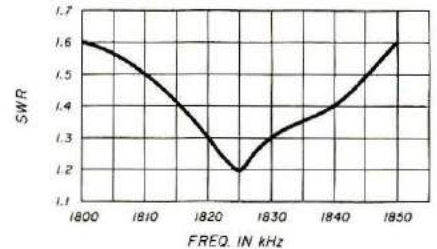

Fig. 2. When the right tap points on the coil are found, the SWR should be low across a good portion of the band.

should only be in the \$25-30 range.

The antenna certainly surmounts the old "I don't have enough room" problem for those who are eager to try top band, and its simplicity makes it a cakewalk for the beginning ham.

Take the plunge and try it. I'm looking forward to hearing more lazy verticals on top band.

HRH

UNDER \$100.00!

HY-GAIN 3806 2-meter handheld transceiver

\$89.95

SAVE \$100!

~~List 189.00~~

While supply lasts.

Add 2.50 shipping & handling.
Item No. 8386.

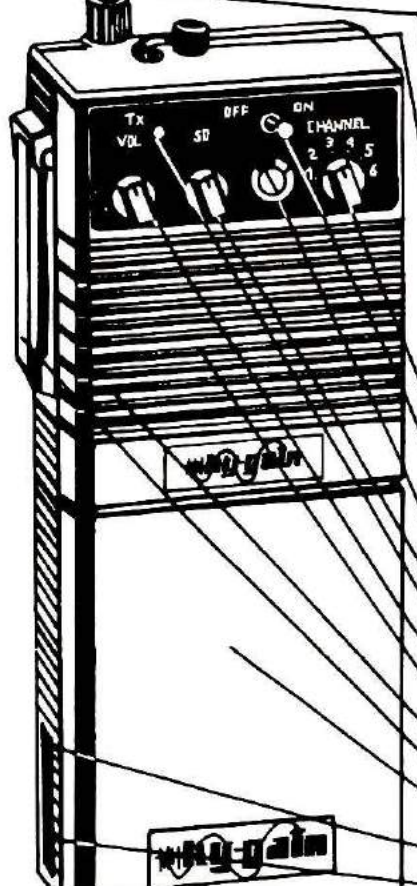

- Interior antenna
- Exterior antenna
- Channel selector
- DC power ON/OFF switch
- Transmitting voltage and receive signal strength indicator
- Squelch volume
- Transmit indicator
- Audio volume
- Internal speaker
- Microphone
- Transmit/receive switch
- Battery case
- Earphone jack
- External DC 12V jack

- Buy a new, lowcost 6 channel handheld which provides superb voice transmissions.
- Sharply tuned on-frequency selectivity in the RF amplifier stages plus FET's in the 1st and 2nd mixers for virtual immunity to out-of-band signals, intermodulation distortion and cross modulation.
- Separate microphone and speaker elements for enhanced audio.
- Internally adjustable mic preamp—a Hy-Gain exclusive.
- Specially gasketed case seals out water, dirt and corrosive salt air.
- Watertight, high-impact ABS plastic case-ribbed for non-slip grip.
- Top mounted controls for instant access
- Comes complete with 146.52 crystals only.
- 1 watt output (12 VDC input)
- Operates on 8 "AA" batteries or optional NiCad battery pack.

Item Number	ACCESSORIES Description	Price
A8302	NiCad battery pack	24.95
A8327	Touch tone pad	29.95
A8304	AC battery charger	4.95
A8309	Cigarette lighter adapter cord	4.95
A8305	Carrying case	14.95
A8328	34/94 crystals	7.95 a pair
A8329	16/76 crystals	7.95 a pair



Optional NiCad battery pack **\$24.95**



Optional touchtone pad (not installed) **\$29.95**

Long's

Ham Radio Department Store

MAIL ORDERS: P.O. BOX 11347 BIRMINGHAM, AL 35202 • STREET ADDRESS: 2808 7TH AVENUE SOUTH BIRMINGHAM, ALABAMA 35233



Use your Master Charge or BankAmericard/VISA when you order.

Call
Toll Free

1-800-633-3410

IN ALABAMA CALL 1-800-292-8668 9 AM TIL 5:30 PM CST, MONDAY THRU FRIDAY

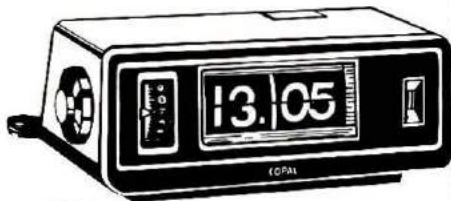

COPAL RP-205 24 hour clock with 24 hour alarm

A highly accurate 24 hr. clock with a 24 hr. alarm system that you can set for either AM or PM and in 10 minute intervals. It also features illuminated leaf type numerals and a precision synchronous motor.

19.00 List. Call for quote.

NEW!



**COPAL QG-500
pocket sized
24 hour
World Timer**

This clock tells the time in 24 world locations. Quartz crystal accuracy using a 4 MHz crystal oscillator, a 24 hr. alarm system that can be set at 5 minute intervals and drum type numerals are some of its many features. With battery power and an LED to show when the clock is running.

99.00 List. Call for quote.



**KENWOOD TR-7625 25W
2m transceiver**

A synthesized transceiver with full 4 MHz coverage 144.00-147.995, 800 channels, 5 KHz offset switch, memory channel with simplex or repeater operation ± 600 KHz transmitter offset, mode switch for selecting the transmit frequency up or down, MHz selector switch, digital freq. display, unlock indicator for transceiver. Connections for the optional RM-76 remote control unit.

425.00 List. Call for quote.

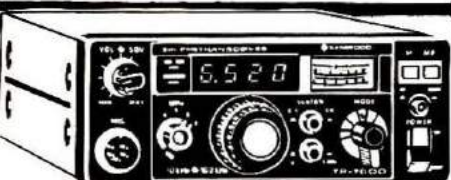

KENWOOD TR-7600 2m FM transceiver

A high performance transceiver with memory, designed for full 4 MHz coverage 144-148, 800 channels. Featuring 10W RF output/1W Lo, memory channel with simplex or repeater offset, 13.8 VDC at 3A continuous. Also LED frequency display & tone pad terminal. Connections for the optional RM-76 remote control unit.

375.00 List. Call for quote.



**KENWOOD TS-700SP all mode
2m transceiver**

Covers the entire 2m band, SSB, CW, FM and AM. Features semi-break-in CW, side tone monitor, digital frequency readout, receiver preamp and 600 KHz repeater offset operation within all 2m repeater subbands including the new 144.5-145.5 MHz. With 10 watts RF output and AC/DC power supply.

799.00 List. Call for quote.



**KENWOOD RM-76
microprocessor
control unit**

Designed for the TR-7625/TR-7600, it has 6 memory channels, MARS channel, scans for either busy or open channels. TX frequency can be shifted ± 600 KHz, scans memory channels. Memory data remains stored even when power switch is off if the power cord is connected.

125.00 List. Call for quote.

**YAESU FT-202R
2m handheld
FM transceiver**

Featuring: 1 watt output minimum, 6 channel capability - 3 prs. of crystals included, flexible helical whip antenna, toneburst, S meter and battery condition indicator, built-in speaker and condenser mic. Compact and light weight. Operates on 8 AA NiCad or 7 AA dry cell batteries.

199.00 List. Call for quote.



Dentron

**DENTRON Clipperton L
linear amplifier**

Hi/Lo power switching, covers 160 thru 15 meters, 2000W PEP SSB, 1000W DC on CW, RTTY, SSTV, continuous duty power supply 2500V idle SSB 1800V idle CW, covers most MARS frequencies, easily changed 117V or 234V AC 50/60 Hz. Final tubes: 4-572B.

699.50 List. Call for quote.

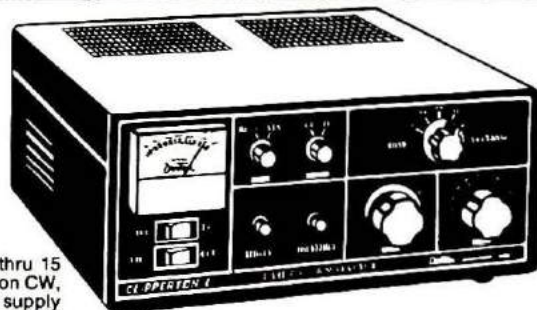

**YAESU
FT-101Z**

high performance HF transceiver

Covers: 160-10 meters plus WWV, modes LSB, USB, and CW, built-in power supply. Input power: 180 watts PEP, analog frequency readout, 6146 final tubes, RF speech processor, variable IF bandwidth (300 Hz - 2.4 KHz), noise blanker, VOX, attenuator 10 dB or 20 dB, 100-234V operation & TX/RX frequency offset.

749.00 List. Call for quote.



**KENWOOD
TS-120S solid state
Hf SSB transceiver**

No tune up! Miniaturized circuits, solid state construction, built-in digital display, IF shift, final transistor protection, VOX, noise blanker, 25 KHz marker. Frequency range is 80-10 meters and WWV. Modes: SSB and CW, 200W SSB & 160W DC CW. Power requirements: RX-0.7 13.8 VDC, TX-18A 13.8 VDC, 9 1/2" x 3 3/4" x 11-9/16".

699.95 List. Call for quote.



**TEN-TEC
Century 21
CW transceiver**

Great for the novice or the dedicated CW operator. It features: full break-in, 70W input, all solid state, built-in speaker, receives CW or SSB but transmits CW only. It has overload protection, offset receiver tuning, linear crystal mixed VFO, adjustable level sidetone, built-in regulated power supply. Crystals are provided to cover the 80-10 meter novice bands.

349.00 List. Call for quote.





Radio equipment
not included

Also Available . . .
Floor Space: 51" Wide by 30" Deep
\$192.50

4384 KEYSTONE AVENUE • CULVER CITY, CALIF. 90230 — PHONE (213) 837-4870

... at last ... your shack organized!

A beautiful piece of furniture — your XYL will love it!

\$16450 S-F RADIO DESK Deluxe - Ready to Assemble

Designed with angled rear shelf for your viewing comfort and ease of operation.

FINISHES: Walnut or Teak Stain.

Floor Space: 39" Wide by 30" Deep

Additional Information on Request.

Checks, Money Orders, BankAmericard
and Master Charge Accepted.

F.O.B. Culver City. (In Calif. Add 6% Sales Tax.)

— DEALER INQUIRIES INVITED —

S-F Amateur Radio Services

\$9

1980 HANDBOOK

BRAND NEW! STEP INTO
THE 80'S WITH THE
LATEST HANDBOOK FROM
THE EDITORS AT ARRL



NEW FOR
1980

Full of exciting new features for the 80's, NOW is the time to order your copy of the 1980 ARRL "RADIO AMATEUR'S HANDBOOK." Internationally recognized and universally consulted, every Amateur should have the latest edition. The new HANDBOOK covers virtually all of the state-of-the-art developments in electronics theory and design. Novices will find it to be an indispensable study guide, while the more advanced Amateur will enjoy building the many new projects.

- Order AR-HB80
Softbound \$10.00
- Order AR-BB80
Hardbound \$15.75

HAM RADIO'S BOOKSTORE

GREENVILLE, N. H. 03048

(800) 258-5353

Hobbyists:

Here is an interesting general electronics hobby magazine. It's loaded with lots of interesting simple circuits and ideas, not only about radio, but in all phases of electronics including test gear, audio, remote control and security systems. We are sure that you will find a number of worthwhile projects in this British magazine.

For a sample copy, please send \$1 to cover postage and handling costs. Your dollar is applied to the cost of the subscription when ordered.

1 Year (12 issues) \$20.00
Radio & Electronics
Constructor
Greenville, NH
03048



MAXI TUNER SOLVES ANTENNA PROBLEMS

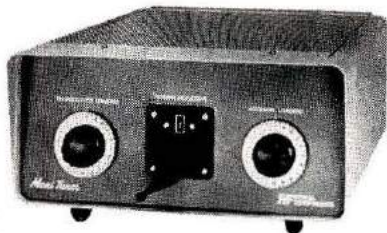

THE FINEST ANTENNA TUNER AVAILABLE

- Presents 50-75 Ohm Resistive Load to Your Transmitter Using Virtually Any Antenna System
- Improved Ultimate Transmatch Circuit Matches Coax, Random Wire and Balanced Antennas
- Continuous 1.7-30 MHz Coverage
- 229-203 Rotary Inductor (28 μH)
- Rugged Cast Aluminum Turns Counter
- Handles 3 KW PEP
- Heavy Duty Balun
- Velvet-Smooth 6 to 1 Vernier Tuning
- 0-100 Logging Scale on Capacitors
- Available in Kit Form or Assembled
- One Year Factory Warranty
- Use with your present SWR meter or wattmeter.
- Custom Vacuum Capacitor Designs and Individual Components Available

Call or Write for Pricing, Spec Sheet, and FREE Amateur Market Antenna Tuner Comparison Chart That Tells It Like It Is!

RF POWER COMPONENTS
P. O. Box 11
Ladysmith, WI 54848
(715) 532-3971



THE NATIONAL MARKETPLACE FOR OWNERS AND BUYERS OF USED AMATEUR EQUIPMENT

1879 POST RD., P.O. BOX 66, SOUTHPORT, CT 06490

HGM matches Buyers with Owners of used equipment. Perfectly! Register gear you want to sell or buy, nationally, for only \$3.73. At least once a week, HGM compares Buyer specifications to all available equipment registered by Owners. For each perfect match, HGM writes Buyers the particulars about the gear. Buyers contact Owners directly, and all negotiations are strictly between Owners and Buyers.

HGM GUARANTEE: Just \$3.73 per registration (a "sell" or a "buy"), and your Registration remains active for 17 unique matchings or 17 months. No HGM commissions! We cannot warrant nor guarantee any equipment found through HGM since everything is between Owners and Buyers. But we do guarantee unique matchings and 17 matchings or months. A fabulous service for the amateur service!

REGISTER NOW. Use this form or facsimile and enclose the \$3.73 fee for each Registration. OWNERS: Describe unit by Type, Brand, and Model. Indicate exact Sell Price and purchase date. BUYERS have two choices. Choice #1: Type or Gear. Indicate Type and one Price Range. Example: Transceiver, \$700-899. Choice #2: Specific Unit, regardless of price. Indicate specific Brand and Model you want. Example: Transceiver, Ten-Tec, Century 21.

YES, hamgearmart, I need your help! I understand your Guarantee, and I'm enclosing \$3.73 with this Registration. Enter my Registration immediately. Please register me as a . . .

OWNER <input type="checkbox"/>		BUYER <input type="checkbox"/>	
SELL PRICE	TYPE OF GEAR	PRICE RANGES	
	XCVR, SCOPE, ETC	A	40 - 99
GEAR YEAR	BRAND NAME	B	100 - 199
		C	200 - 299
PURCHASED	MODEL NUMBER	D	300 - 399
NEW/USED		E	400 - 524
		F	525 - 699
		G	700 - 899
		H	900 - 1099
		I	1100 - 1399
		J	1400 AND UP
NAME	CALL	CLASS	
ADDRESS	TELEPHONE		
CITY	STATE	ZIP	
hamgearmart 1879 Post Road, P.O. Box 66 Southport, Connecticut 06490			

1980
1980
CALLBOOKS
See page 37 for super value
on 1980 Callbooks.
1980

CLOSET HAMSHACK

AN ALL BAND STATION IN A ONE-MAN CLOSET

BY ETHAN WINNING, WD6GKF

There are growing numbers of hams who are living in apartments and condominiums. For those of us who do, or for Amateurs with other space limitations, there is a solution requiring only two prerequisites: an understanding YL and a "useless" closet. Having both has solved a space-age problem for me.

I got my Novice-class license in April, 1978, built most of the Heathkit SB-104 line, and then entered into negotiations with my wife regarding where to put all that gear. Fortunately, we did have a "useless" (as defined by me) closet. The door measures 27 inches across, but the closet is 48 inches wide, leaving most of it inaccessible to clothing hung in the corner. Its location in the master bedroom of our condominium did not concern my wife, who has the ability to fall asleep during even the most exciting QSOs.

The "closet shack," as I pictured it, would be functional, convenient, and as beautiful as I could make it — being a stickler for "organization." Planning would be essential, for closets cannot expand to fit the needs of the Amateur; you can add only as much gear as the closet will hold, so I had to determine exactly what I would be adding. Because I knew that I would go beyond the General-class license, I would need room for 2-

meter and low-band gear. Considering in retrospect, I did not miscalculate by much, but I will admit now that the closet has reached its maximum potential.

I purchased a 36-inch bookcase with solid back and two shelves 15 1/2 inches apart. The bookcase is 18 inches deep, enough to hold the largest of the Heathkit gear, and wide enough to comfortably fit three pieces across. First problem: how to fit a 36-inch-wide bookcase into a 27-inch-wide door. Solution: hold the bookcase on end and lift it through the door, then settle it in sideways. Suggestion: prepare for minor back and arm aches. The bookcase weighs 75 pounds!

Now that it was certain that the bookcase would fit, it had to be removed since I wanted to do something special to the walls inside the closet. Behind the bookcase or shelving (which is perhaps a better idea), "Z-Brick" presents a rather warm or homey appearance. Since that can be expensive (\$40 for a 3 × 4 foot space) one can combine the brick with cedar strips. A \$15 pack of strips will complete the wall space in most areas such as this.

After completing that chore, I added shelves for books, file boxes, and other accessories. These shelves, four in all, are 20 inches wide and 15 inches deep, and go across the deep end of

the closet. The lowest one holds my dummy load and the necessary electrical outlets. The bookcase was then replaced, and the almost finished closet was presentable. Total time: six hours.

Little did I know that this was just the beginning. The pitfalls of limited space operation hadn't even begun to show, but now (a year later) there are many things which I wish I had thought of and done, even prior to buying the bookcase. These are my experiences and suggestions:

- 1. Whether you own or rent,** make certain that the space will be presentable when the equipment is removed, so that either the landlord or a buyer will accept your improvements.

I used as few nails as possible, and installed the book shelves with molly screws. When I did use nails, I used finishing nails which made holes that can be covered with paint. However, I did not use the Z-Brick more than 3 inches past the top of the bookcase. When I remove the shelves, the wall will have to be finished to the base of the closet. Z-Brick is not easily removed; in fact, it may be a permanent installation.

If you think that the landlord will not be pleased with your efforts, then I suggest as tall and wide a cabinet (metal ones

range from \$89 to \$225) as space will allow. Note, also, that if you use a 6- or 8-foot cabinet, you will be able to use a closet with sliding doors, and have everything self-contained.

2. Plan your power requirements.

Most closets don't contain outlets, and if you are going to add a linear amplifier make certain that you can plug it into a separate, heavy-duty circuit (whether or not you can find a 220-volt line).

I was fortunate. The closet is just behind my children's bedroom, and by drilling a 1/4-inch hole through the wall, I could in-

stall a nine-plug receptacle with a cord capable of handling 15 amps. I would be running the transceiver, console, monitor, keyer, 2-meter and high-frequency power supplies, plus some lighting. The nine-plug receptacle has a fuse, as do both power supplies, and I would not be running both high-frequency and 2-meter rigs at the same time. The power-handling capability of the plug and cord were more than adequate for all but the linear. For my SB230 linear, I ran the line direct to another receptacle on the wall in back of the door in the bedroom. It would be the only piece of equipment to run off that circuit.

3. Plan for air circulation. The SB230 is conduction cooled, but in order to get enough circulation to it, it was placed on top of the bookcase where there would be sufficient air movement.

The high-frequency rig power supply was placed in the lowest shelf of the bookcase with the heatsinks facing out toward the room. Although that power supply was designed to go into the speaker cabinet, there would be no air circulation in the back of the bookcase. (Note: during the winter, there is quite a temptation to warm one's bare feet on the heatsinks. DON'T!)

4. Plan your ground system.

This was one of the most ill-conceived ideas on my part, and will never fully be solved for me.

The first problem was that the back of the bookcase was solid. Holes had to be drilled for *all* connections, including the ground from each piece of equipment. Although not entirely satisfactory, 2-inch holes were drilled for the eighteen connections that had to be made. One-inch braid was used from *each* piece of gear to a clamp which was soldered to a 12-gauge solid-copper wire. This wire leads out of the closet and through the casement of a nearby window, then down to an 8-foot grounding rod 17 feet down from the bedroom. Not at all ideal, but perhaps as satisfactory as I could have.

If you have the opportunity, you may be better off going to a cold-water pipe in a nearby bathroom or laundry room. That could not be done in my condominium because there was no cold water pipe within 20 feet of the closet. Perhaps this should be the second step in your planning: after finding a closet or other space, check for your grounding needs.

A suggestion from my experi-



Relaxed, and ready for a pleasant evening of hamming; the equipment is in place, ready to reach the world from my condominium.

ence: do not use a solid back bookcase, and if at all possible, use open shelving. True, the wires will be more in evidence and the "shack" will not look as good, but the problems of hooking up the gear and ground will be ten times easier than the system I now have. It is the bane of my closet existence. Further, when I have to remove a piece of equipment, it can take up to half an hour, and I need a coat hanger to fish for the connections when it is being replaced.

Of course, also keep in mind that the objective is to have something as nice looking as possible. Aside from your own desires (which may not include the appearance), it keeps your wife or husband happier.

5. Plan for comfort. I have still not solved the problem of what to do with my key, but, as a temporary measure I use a removable board attached to the closet door.

Some of you will not have doors or anything which will suffice. If CW is your thing, I suggest purchasing a small typing table on wheels, which will give adequate space for key and writing. Actually, I use the only thing that I have handy — my lap. But that is what has forced me into SSB rather than more CW operation.

Lighting is very important. I have hooked up four very small spots to light the bookshelves and wall (with clock, license, and awards), and one swiveling piano lamp on the door to light the work area and front panels of all the equipment.

Any comfortable chair will do, but I do suggest one on casters. Most bedrooms have carpeting, and a chair without casters is extremely inconvenient. Be certain that the casters are made for the kind of surface the chair will be on. If the floor is hardwood or linoleum rubber casters are a must; otherwise, you may "scoot" back into another room.

Make use of the door if you have one. Other than a bulletin board, and some cork for maps

and QSL cards, I placed two file holders on the door to hold writing pad, log book, a small atlas, and a ready supply of QSL cards. Everything I need is within reach.

I have left the most important item in planning for last, a topic which could be (and has been) an article in itself: the antenna. My situation is as ideal as one can have when no outdoor antennas are allowed (and the pine trees have not grown sufficiently to hide one). Our condominium is two stories high and has an attic, an attic located just above the closet. I was able to drill two small holes in the ceiling of the closet for the high-frequency and two-meter anten-

na transmission lines. This is not to say that I didn't have difficulties; the attic is 39 feet long, 16 to 18 feet wide, and only 43 inches high at its peak. This can be quite limiting (and debilitating, as my chiropractor will attest — my relationship with him stems from an unplanned descent through that attic floor; be forewarned!).

My 2-meter antenna is a small Ringo, tied with rope to one of the struts. The antenna is 42 inches tall, leaving a whole inch with which to play around. It works beautifully!

The low-band antenna is a five-band trap dipole, 107 feet long with traps, and currently (and forever) in a rectangular



Making the most of the space available. The transceivers and power supplies fit neatly on shelves in the closet. The closet door, when open, reveals a collection of the most interesting or most recent QSL cards, some maps, a holder for log books and writing supplies, and even a telephone. With the door closed, my "hamshack" is out of sight, leaving a nearby TV set as the center of attention.

shape. The ends of the dipole come within three feet of touching. The propagation pattern has not been deciphered, but its longest legs are broadside northwest/southeast. (That does not explain why I can get into New Zealand with consistently good reports, and into Australia with consistently poor ones.)

The specifications for the antenna are listed in the 1977 *Radio Amateurs Handbook* and another ARRL publication, *Understanding Amateur Radio*. The capacitors used in the traps are difficult, but not impossible, to obtain.

Physically, the antenna is 12-gauge copper wire, and, although I wish I had used stranded, it is solid. There is no balun. The antenna, at least in a certain condominium in Walnut Creek, is resonant at 3965 kHz, and has a 1:1.5 or better match on the General-class portions of 80, 40, and 15 meters.

This is not to imply that there are no problems with an attic dipole. I have had one complaint from a neighbor who was having stereo interference; he was using 25 feet of zip cord for speaker leads!

Other than that, I have considerable TVI in my own house, both upstairs and down, and stereo interference in all but one. However, proper filtering will solve the stereo interference, and the TVI will probably remain on channels 2, 3, and 4. I just do not transmit when my family is watching TV. (Besides, most of the "good" DX doesn't start until after "prime time.")

When you are in the near (NEAR) field of an antenna, and running 1250 watts PEP, you have to expect such problems. However, as long as it is only within your own house, the problems are minimal. And, given time, I will be able to filter those problems out as well. I do have one "clean" TV and one clean stereo. Therefore, it must be possible to filter the rest.

Last, when our home was built, telephone lines were

(almost literally) thrown into the attic. As severe as that problem (telephone interference) was, the phone company was able to install special phones which cleared up that situation.

Now that I have my Advanced-class license, and because I do want to get on 10 and 20 meters, I use a Dentron Super Tuner Plus, and can work any portion of all five bands.

And I do work them! Since July, 1978, I have worked ninety-three countries and all states (on two bands). And, the reports have been quite good: a 5x6 in Cape Town, South Africa; 5x9 + in Djakarta, Indonesia; 20 over S9 in Alma Atta, Russia; and 40 over S9 in Sweden. I have also had some terrible reports, but all of this has taught me some interesting things and made me develop a healthy philosophy.

When you work out of a closet, and run an indoor trap dipole, you *need* a philosophy to counter the beam-and-2-kW addicts! I received a 5x9 report from Angola a few weeks ago, and spent an enjoyable ten minutes discussing the shack and antenna. Angola is perhaps 10,000 miles from me, and is the best report I have had from that far away. If I can do that once, I can do it again. If I can get to Angola, I can get to other parts of Africa and the rest of the world. And, as I once did, if I can get into Europe on 10 watts, then *propagation is everything*. Further, while the fellow with a beam may be able to do a better job, get better reports *sometimes*, win in some of the pile-ups *faster* (but not always more frequently) than I, I have a "challenge," and it makes my DX contacts more enjoyable and exciting. To be able to get one-hundred countries in a month, or two-hundred in a year, with the use of a linear and beam is not half as enjoyable — for me — as finally getting into a country and saying I'm working off an indoor dipole. (That statement usually prolongs any QSO).

Visitors to the "shack" have been very complimentary. With

the door closed, you see nothing but a couple of wires coming out from under the door. Open the door, and there have been statements of utter amazement.

Hams in the Diablo Valley have called it the most beautiful shack they've seen (honest), and non-Amateurs have difficulty thinking of it as a "radio station." The QSL cards (there is room for only eighteen) are displayed on the door, and I purposely use at least one from each continent, and some which boldly announce the country of origin for the benefit of non-Amateurs.

I sometimes send pictures of the closet to other hams I have talked with. A Japanese ham said it was a "most beautiful room, and is of great interest in a country where space is so limited." An Amateur in Scotland wrote, "I love your radio room, and have seen none more pleasantly appointed." And, another in Scotland said, "I hope you can find room on your door for this card." (I did). My South Africa contact said, "I still don't believe you are running an indoor dipole," and the editor of a California ham publication said, "I'll say it one more time — I LOVE this station."

I don't know what more I could add. My wife is pleased. My kids invite other kids to see the closet, and their comments range from, "WOW" and "GEE WHIZ" to "SO WHAT!" There are, of course, some inconveniences, but I really do not mind. Every evening as I sit by the door, I know I've got the nicest closet in town! It is possible to have a closet that is not a closet, and a "shack" that is not a shack. Space limitations may well be in the mind rather than in the physical layout. For those of you who would rather have cluttered areas, a final note: don't let your YLs or OMs see these pictures. Some of the hams I have sent pictures to have told me that NOW they have been coerced into "cleaning up their acts" ... so to speak.

HRH

Operate **Legally** Without An FCC License in the 160-190 kHz Band

LOW & MEDIUM FREQUENCY RADIO SCRAP-BOOK (3rd Edition) by Ken Cornell, W2IMB

Here's your chance to get on the air and have some legal license-free excitement in the 160-190 kHz range. Explore the enticing world of the low frequencies and uncover some new fun! Complete details on assembling homebrew to work these frequencies plus full info on FCC rules and regulations. A book you just can't afford to miss. 110 pages. ©1977.

HR-LF **Softbound \$6.95**

ADDENDUM '77/'78 for the Low & Medium Frequency Radio Scrapbook by Ken Cornell, W2IMB

Even more goodies from the 160-190 kHz region. Addendum '77/'78 is designed to complement **The Low & Medium Frequency Radio Scrapbook**. The technical data is excellent and will provide you "lowfers" even more information, applications, and techniques for these enticing frequencies. Latest revised FCC rules governing the non-licensed communication bands 68 pages. ©1977.

HR-LFA **Softbound \$3.95**

Be a LOWFER

Join the fun and get on 160-190 kHz this winter

HR-LF **\$6.95** Send your order today or call

HR-LFA **\$3.95** **TOLL FREE**

Plus shipping **\$1.00** **1 (800) 258-5353**

Total enclosed _____ Clip & Mail Today!

Charge MC VISA

Expiration _____ Card Number _____

Name _____

Address _____

City _____ State _____ Zip _____

HAM RADIO'S BOOKSTORE
GREENVILLE, NEW HAMPSHIRE 03048

Order Your Collins KWM-380 NOW!

and receive FREE

(+ old pricing, deposit only required)

- 1) Noise Blanker — \$195.00
- 2) or 2 Filters, your choice — \$96.00 ea.
- 3) or Blower Kit — \$195.00



Get on with the Best!

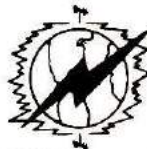

MADISON

Electronics Supply, Inc.

1508 McKinney • Houston, Texas 77002 • (713) 658-0268



July 26 thru August 8, 1980

Our 21st year of successful teaching

**Boost your Ham Skills
on the Blue Ridge**

"A Vacation with a Purpose"

Two weeks saturation learning program in Amateur Radio:

- Novice to General
- General or Technician to Advanced
- Advanced to Amateur Extra

Expert Instruction starting at your level. Code and Theory in depth along with Friendly Amateurs, Who Care About You.

C. L. PETERS, K4DNJ, Director
Oak Hill Academy Amateur Radio Session
Mouth of Wilson, Virginia 24363

Name _____ Call _____

Address _____

City/State/Zip _____

NEW 80 & 84-METER TRANSCEIVERS

ONLY \$79.95 EACH

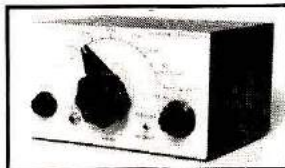

PPD U.S.A. LESS BATTERIES

- 84-meter transceiver which covers 3500 to 3600 kHz is for the old timer.
- NOVICES should order the 80-meter unit which covers 3685 to 3755 kHz.
- CW operation with VFO control.
- Output power approximately 1/2 watt.
- Expect up to 1000 mile range when used with a half-wave dipole.
- Adjustable RF output impedance.
- Low distortion sidetone oscillator doubles as a code practice oscillator.
- Direct conversion receiver.
- RF amplifier and sharp audio filter.
- Receiver independent tuning.
- Long life operation from 9 self-contained 1.5 volt carbon-zinc D cells.
- Size 9" wide by 5" high by 8" deep.
- Instruction manual included.

Accessories required but not included, are 8-ohm stereo phones, telegraph key, a good antenna such as a half-wave dipole, and a dc voltmeter.

MANUAL AVAILABLE SEP. \$2.00
SEND S.A.S.E. FOR SPEC SHEET
R.I. RESIDENTS ADD 6% SALES TAX

TEDCO

9 Canonicus Avenue
Newport, Rhode Island
02840

Upgrade Your CW Easily

DATONG



Model D70 MORSE TUTOR

- Produces random five character groups: all letters, all figures, or mixed.
- Calibrated variable speed (6 1/2 to 37 words per minute) and variable delay (up to 3 seconds) between letters for optimum learning efficiency.
- Internal loudspeaker, plus personal ear-piece for private listening. And pocket size.
- Battery operated therefore always ready for use. Current drain is very low for long battery life.
- Eleven IC, CMOS circuit for long internal battery life.
- Built-in tone oscillator for sending practice (key required).

\$139.95 Including Pre-Paid Shipping & Full Insurance
Dealer Inquiries Invited
Made in England • 90 Day Warranty
Visa-Mastercharge Accepted

(Exclusive Importers of DATONG FL-1's)

AR Technical Products Corp. Dedicated to Excellence

Box 62
Birmingham, Michigan 48010
Telephone 313/644-5698

Towering Aspirations

BY MICHAEL SLEPIAN, WB2LKO

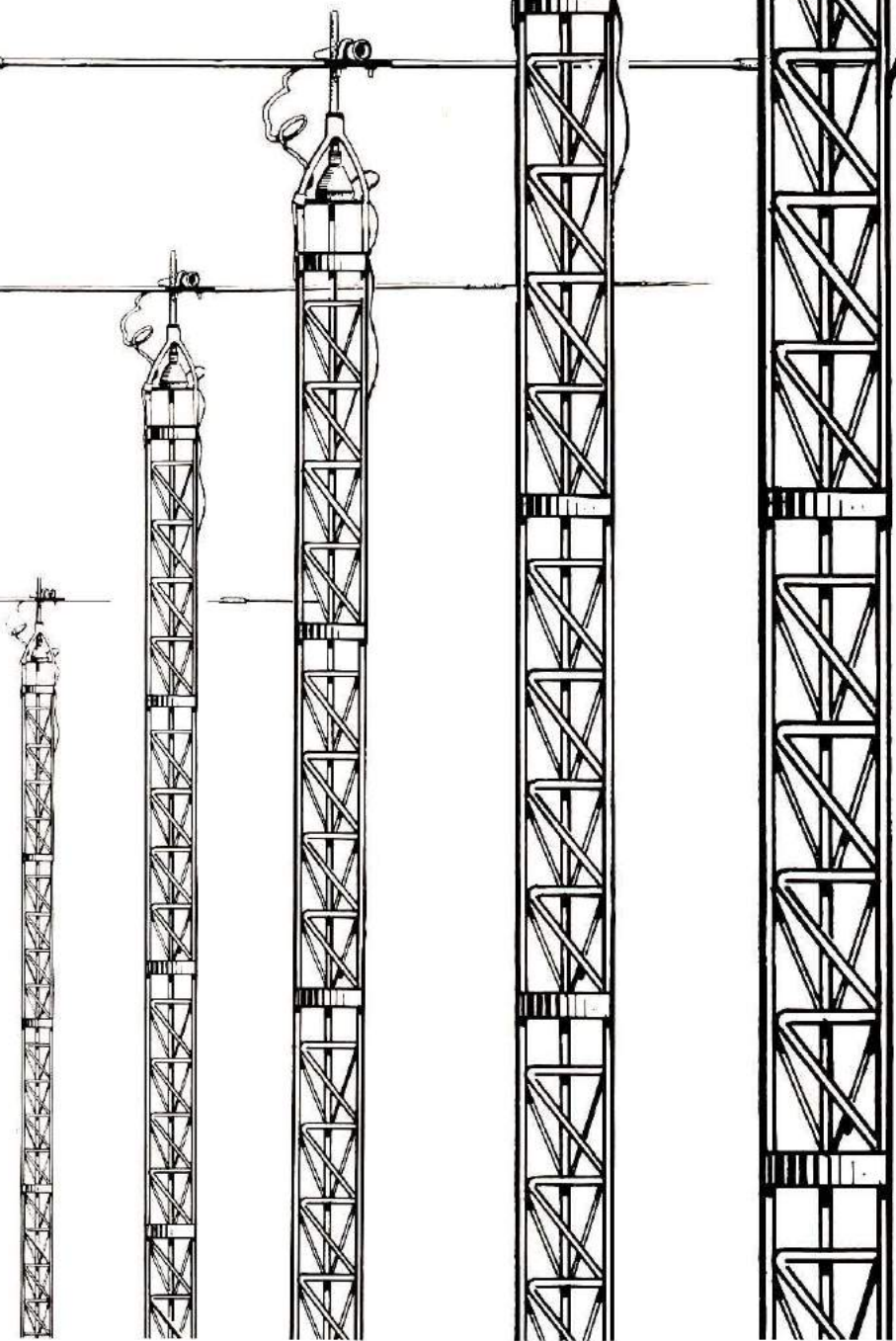

In the world of radio performance, the antenna can be the star, and we often read of its latest exploits. No star, however, can succeed without a great supporting cast, and in many cases that support

comes from an important — but often neglected — performer, the tower. They say experience is the best teacher, and having installed my own tower, I'd like to share my newly acquired knowledge with you.

Do I need a tower?

Since I make my living by producing and directing television commercials, I decided to think of my installation as a film project; of course, I appointed myself director. My first task was casting. What type of antenna did I want? Many antennas, like the dipole I was using at the time, do not require a tower for support. Mine made use of trees, which are plentiful on my lot. Vertical antennas are often ground-mounted, or they might be found sprouting from a roof, held there by a simple tripod.

To achieve the gain and directional characteristics I desired, I decided to make a three-element rotatable beam my star. Naturally, budget limitations have a way of creeping into the picture, so I considered mounting my antenna on the roof, using a tripod. This method has two disadvantages. First, whenever a structure is bolted to the roof, the possibility of leaks presents itself. Also, and of even greater importance, there is the matter of structural strength. Many rotors, when installed on a tripod, must be placed on the mast, above the tripod. This means the entire cast of characters will be "sticking their necks out," and guy wires will be required for even marginal security when it's windy.

Setting

Since my script called for a

tower, my next challenge was choosing the proper setting. It is imperative to *stay clear of all power lines!* All antenna and tower manufacturers include a stern warning that their products are excellent conductors of electricity, and should never be erected within falling distance of power lines. If any part of the assembly were to come in contact with even the service lines that enter your house, *you could be killed!* Keep in mind the size of your antenna once it is assembled. Will it clear all power lines and other cables entering your house, as you haul it up the tower for final placement on the mast?

Before I went any further, I decided to check on my star's popularity rating. My checklist included the following points:

1. Does the proposed structure comply with all local building codes? The town my tower is in does not seem to be overly concerned, as long as the installation is being used for non-commercial purposes. Your town may be just as accommodating, but it's wise to check first.
2. How does my insurance agent feel about towers? Does my homeowner's policy cover damage to the tower, and damage that may be inflicted on my house if the tower should collapse, or take a lightning stroke?
3. Will my antenna extend beyond my property line, violating my neighbor's property? I did not wish to be responsible for damage which might be caused by ice falling from my antenna, onto my neighbor's house.
4. Even though I was directing this extravaganza, final approval had to be obtained from the executive producer, my wife.

Casting was almost complete. All that remained was the decision as to the type of tower to be erected. There are two main types, and both have variations. The first main tower category is the self-supporting

variety. This type may have tapered sections, the widest being at the bottom with each ascending section getting narrower. The crank-up tower is generally included in the self-supporting category. Crank-ups are made of sections which "nest," one inside the other, as it is lowered. This type of tower allows you to perform antenna installation and maintenance without scaling great heights. Also, if high winds are expected, the tower can be lowered to better withstand the

rigors of mother nature. Many crank-up towers use electric winches, making the job of raising and lowering the structure easier and safer.

The second, and probably more popular, variety is the supported tower. Guy wires or brackets — or a combination of both — may be used, depending on tower design, height, and anticipated wind conditions. Literature supplied by the manufacturers will help you determine the amount of "moral support" your tower will

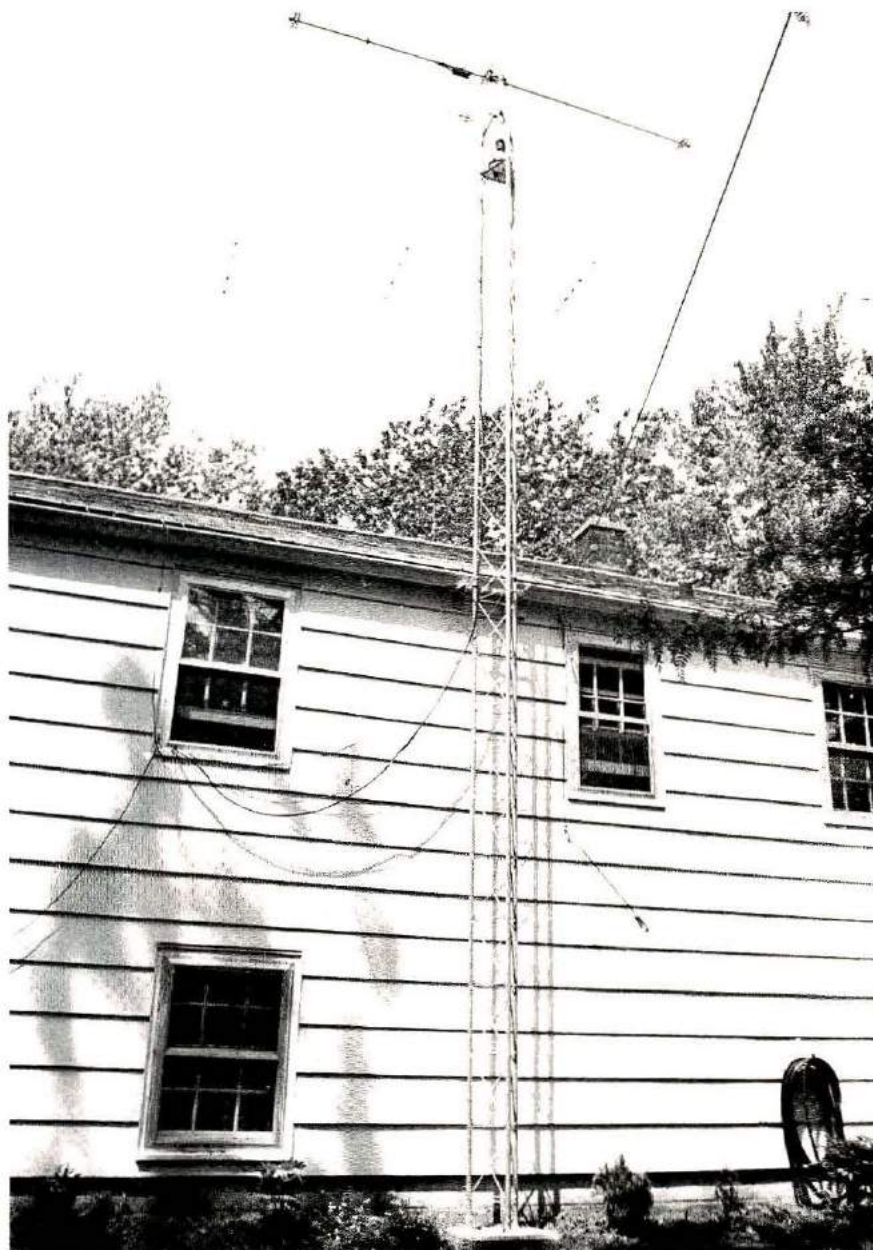

The completed installation, with the tower bracketed to the side of the house, and the transmission line and rotor cables entering the shack by means of a convenient window.

require. If you have adequate space, you may wish to choose a tilt-over tower. You'll enjoy the same advantages the crank-up type offers. Obviously, however, you'll need enough room on your property to accommodate the tower as it lies flat. Care must also be taken, when raising or lowering a tilt-over arrangement, to prevent twisting of the tower sections.

If your scenario calls for a guyed-tower installation, find out, based on manufacturer's recommendations, the number of guy wires you'll need and where they must be anchored. If your property isn't big enough for guy wires, don't despair. A bracketed tower may save the script.

Bracketing a tower to an adjoining structure, such as the side of a house, adds extra strength and stability to your installation. Unless your tower exceeds designed height limitations for bracketed towers, no guy wires are normally needed.

Rigging, digging, and concrete mixing

Before beginning construction, one more part of my "screenplay" still was to be settled. I had to decide on the type of base my tower would rest on. Soil conditions play a large part in determining your choice here. Loose, sandy earth will require a larger base.

Not only did my "production" introduce me to the riggers world, but to the joys of digging and of concrete mixing. Soil conditions at my location in western New York state consist of about one meter (3 feet) of good topsoil and fairly hard packed ground, over a rocky foundation. According to the instructions from the manufacturer of my tower, this called for a hole approximately one meter (3 feet) deep, and 45 centimeters (18 inches) square.

At this point, you'll be presented with yet another choice. You may use either a special tower base section which is placed in the hole and encased



A bracket to hold the tower to the house will take the place of guy wires — up to a modest height, at least. The brackets are adjustable, but some wood shims were needed to be sure the tower was exactly plumb.

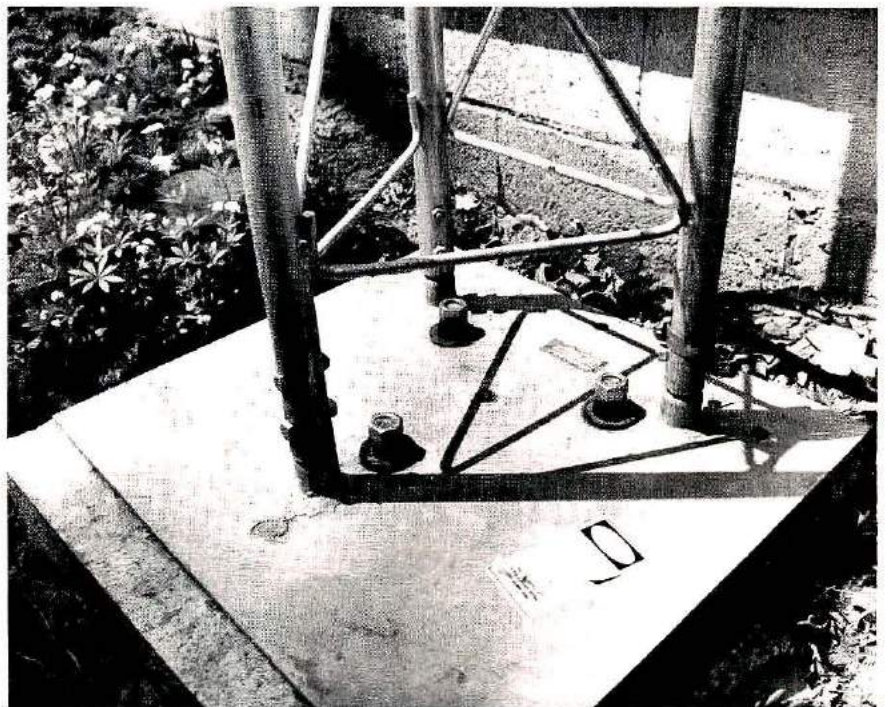

A good base is a must for a secure and long-lasting tower installation. The concrete is poured according to recommendations of the tower manufacturer, and the flat steel plate tower base is carefully leveled and bolted in place. A heavy cable clamped to the right leg runs to a ground rod for lightning protection.

in concrete, or a flat base-plate, held in place with concrete anchor bolts. If a base section is used, be sure it is plumb. In other words, it must be perfectly level and true. Also, never put an aluminum tower section in concrete, as serious corrosion may result. If you use a flat base-plate, it, too, must be level. Failure to follow these standards may result in construction of your own "leaning tower of Pisa!" Here is one more important point to remember: Before digging, make certain you locate your base so that when your tower is raised, the lag bolts which attach the bracket to the house pass through studs, not just the siding.

Dig you must!

This was the part I did not look forward to. Since I did not have access to a post-hole digger, a large shovel was put to the muscle-straining, back-breaking task of digging the foundation hole for my tower. Fortunately, the dirt I removed made a valuable contribution to the flower bed, my wife's favorite outdoor project. When the hole was completed, I took the advice of a gentleman who installs large signs and signposts such as those found at gas-line stations. He provided me with a motley collection of old bricks, pipes, and pieces of steel beams to toss in the hole. This material acts as a binder, adding strength to the concrete mix once it is poured into the foundation. The concrete is mixed with water according to the directions which are usually printed on the bag. You may want to mix one bag at a time, in a wheelbarrow, then simply pour the mixture into the hole.

Be sure to fill the entire hole in one afternoon, allowing the concrete to harden in one solid mass. If you are using anchor bolts to tie down your base, position them with the help of a wooden template, so they will be properly aligned to accept the base after the concrete has hardened. As the directions

supplied with the concrete will probably note, you should wait a few days after pouring the base before doing any further work on your tower, giving the foundation ample time to cure, or harden.

Grounding

Proper grounding of the installation is important for ample protection against lightning. Again, local soil conditions dictate the type of grounding methods you must use. Many hams I have talked with during the research phase of my project have suggested using copper pipe driven into the ground approximately 2½ meters (8 feet). Since copper pipe is quite soft, care must be taken while driving it into the earth. Flooding the soil with water will make your task easier.

The connection to the tower should be made with a heavy gauge copper wire, equivalent to at least a No. 10 (2.6 mm) wire. Make a good electrical connection at the base of the tower, with a straight run as short as possible to the grounding point. Your feedline must be protected against lightning too, since coax cable, such as RG-8/U, is heavy enough to easily route a lightning surge into your shack, causing serious damage to your equipment, at the very least. Several types of commercial lightning arrestors can be purchased to provide protection and peace of mind. These devices are connected "in line," joining two pieces of coax, and subsequently grounded to your tower. Even with this safety precaution, I generally disconnect my antennas from my gear during a severe electrical storm.

Well, now the stage is set. You're ready to begin your own production of "Towering Aspirations." With careful planning, and the right amount of caution, your new tower can be a source of pride, and a ticket to award-winning DX.

HRH

Reliability Service Experience



CDE T-2X

\$197.00
prepaid

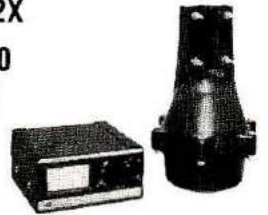

CDE
HAM IV
\$145.00
prepaid

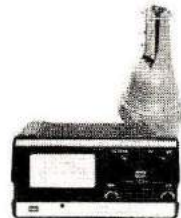

ALLIANCE
HD-73

\$109.95
prepaid

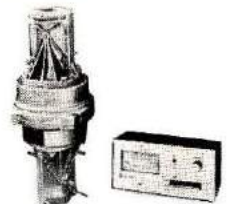

KENWOOD
TR-2400

Check our price last!



PREPAID SHIPPING
CONTINENTAL 48 ONLY



Quantities limited. Michigan residents add 4% sales tax. Please include your area code and telephone number with any correspondence.



RSE HAM SHACK



1207 W. 14 MILE, CLAWSON, MI 48017
(313) 435-5660

31155 PLYMOUTH, LIVONIA, MI 48150
(313) 522-4232

MAIL ORDER TELEPHONE
(313) 435-5660

WILSON SYSTEMS INC. MULTI-BAND ANTENNAS

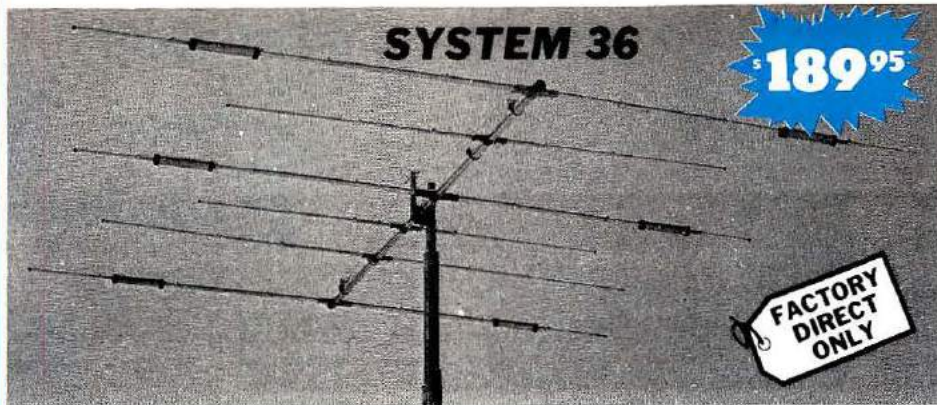

A trap loaded antenna that performs like a monobander! That's the characteristic of this six element three band beam. Through the use of wide spacing and interlacing of elements, the following is possible: three active elements on 20, three active elements on 15 and four active elements on 10 meters. No need to run separate coax feed lines for each band, as the bandswitching is automatically made via the High-Q Wilson traps. Designed to handle the maximum legal power, the traps are capped at each end to provide a weather-proof seal against rain and dust. The special High-Q traps are the strongest available in the industry today.

SPECIFICATIONS

Band MHz 14-21-28
 Maximum power input . . . Legal Limit
 Gain (dbd) Call Factory
 VSWR @ resonance 1.3:1
 Impedance 50 ohm
 F/B Ratio Call Factory

Boom (O.D. x Length) . . . 2" x 24' 2 1/2"
 No. of Elements 6
 Longest Element 28' 2 1/2"
 Turning Radius 18' 6"
 Maximum mast diameter . 2"
 Surface area 8.6 sq. ft.

Matching Method Beta
 Wind Loading @ 80 mph . . 215 lbs.
 Maximum wind survival . . 100 mph
 Feed method Coaxial Balun (supplied)
 Assembled weight (approx) . 53 lbs.
 Shipping weight (approx) . . 62 lbs.

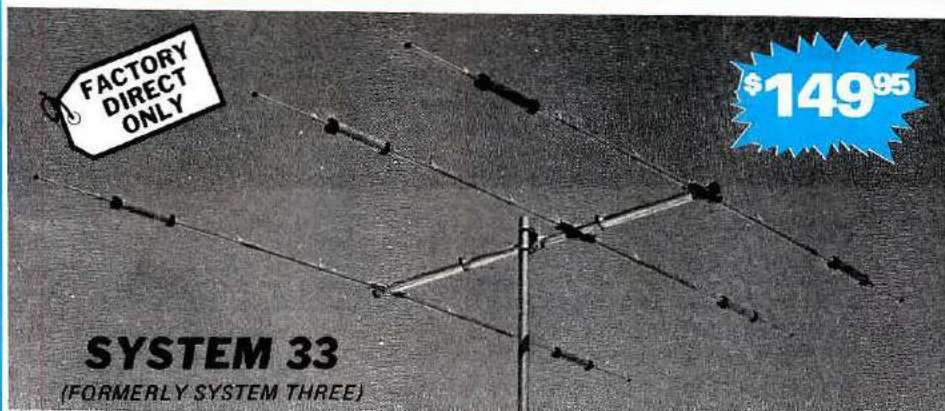
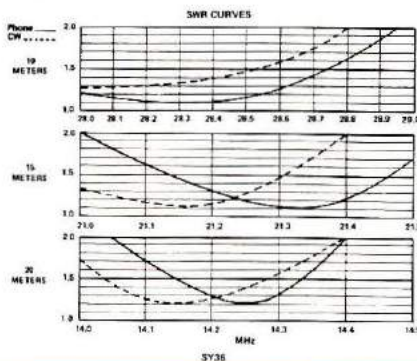

SYSTEM 33 (FORMERLY SYSTEM THREE)

Capable of handling the Legal Limit, the "SYSTEM 33" is the finest compact tri-bander available to the amateur. Designed and produced by one of the world's largest antenna manufacturers, the traditional quality of workmanship and materials excels with the "SYSTEM 33". New boom-to-element mount consists of two 1/8" thick formed aluminum plates that will provide more clamping and holding strength to prevent element misalignment. Superior clamping power is obtained with the use of a rugged 1/4" thick aluminum plate for boom to mast mounting. The use of large diameter High-Q traps in the "SYSTEM 33" makes it a high performing tri-bander and at a very economical price. A complete step-by-step illustrated instruction manual guides you to easy assembly and the lightweight antenna makes installation of the "SYSTEM 33" quick and simple.

SPECIFICATIONS

Band MHz 14-21-28
 Maximum power input . . . Legal Limit
 Gain (dbd) Call Factory
 VSWR at resonance 1.3:1
 Impedance 50 ohms
 F/B Ratio Call Factory

Boom (O.D. x length) . . . 2" x 14' 4"
 No. of elements 3
 Longest element 27' 4"
 Turning radius 15' 9"
 Maximum mast diameter . 2" O.D.
 Surface area 5.7 sq. ft.

Wind loading at 80 mph . . . 114 lbs.
 Assembled weight (approx) . 37 lbs.
 Shipping weight (approx) . . 42 lbs.
 Direct 52 ohm feed — no balun required
 Maximum wind survival . . . 100 mph

W S I WILSON SYSTEMS, INC.

4286 S. Polaris Ave., Las Vegas, Nevada 89103

Prices and specifications subject to change without notice.

ORDER FACTORY DIRECT 1-800-634-6898

\$49.85

WV-1A

4 BAND TRAP VERTICAL (10 - 40 METERS)

No bandswitching necessary with this vertical. An excellent low cost DX antenna with an electrical quarter wavelength on each band and low angle radiation. Advanced design provides low SWR and exceptionally flat response across the full width of each band.

Featured is the Wilson large diameter High-Q traps which will maintain resonant points with varying temperatures and humidity.

Easily assembled, the WV-1A is supplied with a hot dipped galvanized base mount bracket to attach to vent pipe or to a mast driven in the ground.

Note:

Radials are required for peak operation. (See GR-1 below)

SPECIFICATIONS

- 19' total height
- Self supporting — no guys required
- Weight — 14 lbs.
- Input impedance: 50 Ω
- Powerhandling capability: Legal Limit
- Two High-Q traps with large diameter coils
- Low angle radiation
- Omnidirectional performance
- Taper swaged aluminum tubing
- Automatic bandswitching
- Mast bracket furnished
- SWR: 1.1:1 or less on all bands

GR-1

\$10.85

The GR-1 is the complete ground radial kit for the WV-1A. It consists of: 150' of 7/14 stranded copper wire and heavy duty egg insulators, instructions. The GR-1 will increase the efficiency of the GR-1 by providing the correct counterpoise.

WILSON MONO-BAND BEAMS

FACTORY DIRECT ONLY

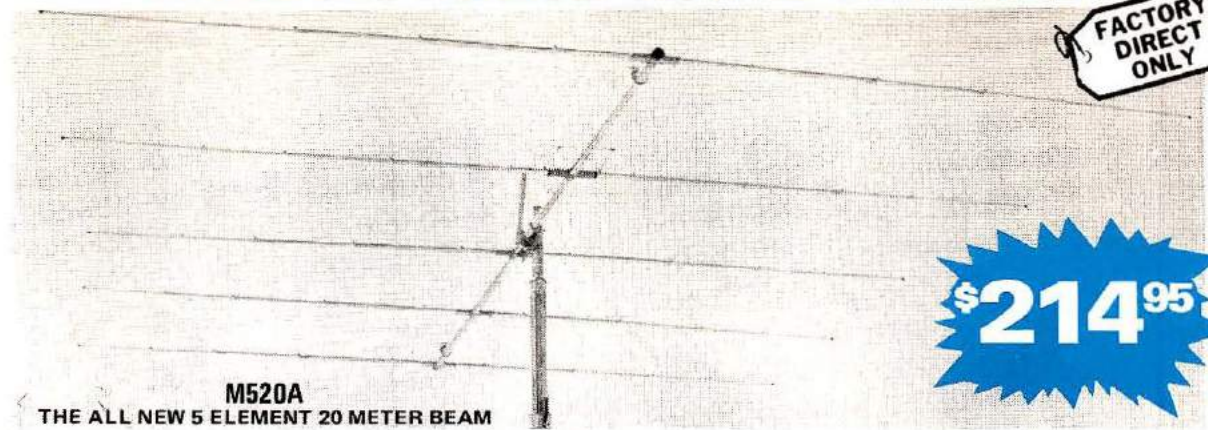

\$214⁹⁵

M520A

THE ALL NEW 5 ELEMENT 20 METER BEAM

At last, the antennas that you have been waiting for are here! The top quality, optimum spaced, and newest designed monobanders. The Wilson System's new Monoband beams are the latest in modern design and incorporate the latest in design principles utilizing some of the strongest materials available. Through the select use of the current production of aluminum and the new boom-to-element plates, the Wilson Systems' antennas will stay up when others are falling down due to heavy ice loading or strong winds. Note the following features:

- 1. Taper Swaged Elements** — The taper swaged elements provide strength where it counts and lowers the wind loading more efficiently than the conventional method of telescoping elements of different sizes.
- 2. Mounting Plates — Element to Boom** — The new formed aluminum plates provide the strongest method of mounting the elements to the boom that is available in the entire market today. No longer will the elements tilt out of line if a bird should land on one end of the element.
- 3. Mounting Plates — Boom to Mast** — Rugged 1/4" thick aluminum plates are used in combination with sturdy U-bolts and saddles for superior clamping power.
- 4. Holes** — There are no holes drilled in the elements of the Wilson HF Monobanders. The careful attention given to the design has made it possible to eliminate this requirement as the use of holes adds an unnecessary weak point to the antenna boom.

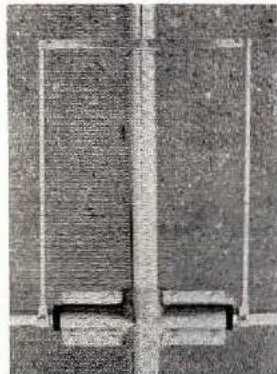

Wilson's Beta match offers maximum power transfer.

With the Wilson Beta-match method, it is a "set it and forget it" process. You can now assemble the antenna on the ground, and using the guide-lines from the detailed instruction manual, adjust the tuning of the Beta-match so that it will remain set when raised to the top of the tower.

The Wilson Beta-match offers the ability to adjust the terminating impedance that is far superior to the other matching methods including the Gamma match and other Beta matches. As this method of matching requires a balanced line it will be necessary to use a 1:1 balun, or RF choke, for the most efficient use of the HF Monobanders.

The Wilson Monobanders are the perfect answer to the Ham who wants to stack antennas for maximum utilization of space and gain. They offer the most economical method to have more antenna for less money with better gain and maximum strength. Order yours today and see why the serious DXers are running up that impressive score in contests and number of countries worked.

SPECIFICATIONS

Model	Band Mtrs	Gain dBd	F/B Ratio	Bandwidth (MHz)	VSWR @ Resonance	Impedance	Matching	Elements	Longest Element	Boom O.D.	Boom Length	Turning Radius	Surface Area (Sq.Ft.)	Windload @ 50 mph (Lbs./ft.)	Maximum Mast	Assembled Weight (Lbs.)
M520A	20	11.5	25 dB	500 KHz	1.1:1	50 Ω	Beta	5	36'6"	2"	34'2 1/2"	25'1"	8.9	227	2"	68
M420A	20	10.0	25 dB	500 KHz	1.1:1	50 Ω	Beta	4	36'6"	2"	26'0"	22'6"	7.6	189	2"	50
M515A	15	12.0	25 dB	400 KHz	1.1:1	50 Ω	Beta	5	25'3"	2"	28'0"	17'6"	4.2	107	2"	41
M415A	15	10.0	25 dB	400 KHz	1.1:1	50 Ω	Beta	4	24'2 1/2"	2"	17'0"	14'11"	3.1	54	2"	25
M510A	10	12.0	25 dB	1.5 MHz	1.1:1	50 Ω	Beta	5	18'6"	2"	28'0"	16'0"	2.8	72	2"	36
M410A	10	10.0	25 dB	1.5 MHz	1.1:1	50 Ω	Beta	4	18'3"	2"	12'11"	11'3"	1.4	36	2"	20

WILSON SYSTEMS, INC. — 4286 S. Polaris
Las Vegas, NV 89103 — (702) 739-7401

FACTORY DIRECT ORDER BLANK

Toll-Free Order Number
1-800-634-6898

WILSON SYSTEMS ANTENNAS

WILSON SYSTEMS TOWERS

Qty	Model	Description	Shipping	Price
	SY33	3 Ele. Tribander for 10, 15, 20 Mtrs.	UPS	\$149.95
	SY36	6 Ele. Tribander for 10, 15, 20 Mtrs.	UPS	199.95
	WV-1A	Trap Vertical for 10, 15, 20, 40 Mtrs.	UPS	49.95
	GR-1	Ground Radials for WV-1A	UPS	10.95
	M-520A	5 Elements on 20 Mtrs.	TRUCK	214.95
	M-420A	4 Elements on 20 Mtrs.	UPS	149.95
	M-515A	5 Elements on 15 Mtrs.	UPS	129.95
	M-415A	4 Elements on 15 Mtrs.	UPS	84.95
	M-510A	5 Elements on 10 Mtrs.	UPS	84.95
	M-410A	4 Elements on 10 Mtrs.	UPS	69.95
	WM-62A	Mobile Antenna: 5/8 λ on 2, 1/4 λ on 6	UPS	19.95
ACCESSORIES				
	HD-73	Alliance Heavy Duty Rotor	UPS	109.95
	RC-8C	8/C Rotor Cable	UPS	.12/ft.
	RG-8U	RG-8U Foam-Ultra Flexible Coaxial Cable. 38 strand center conductor, 11 gauge	UPS	.21/ft.

Qty.	Model	Description	Shipping	Price
	TT-45B	Freestanding 45' Tubular Tower	TRUCK	\$279.95
	RB-45B	Rotating Base for TT-45A w/tilt over feature	TRUCK	179.95
	FB-45B	Fixed Base for TT-45A w/tilt over feature	TRUCK	114.95
	MT-61B	Freestanding 61' Tubular Tower	TRUCK	489.95
	RB-61B	Rotating Base for MT-61A w/tilt over feature	TRUCK	249.95
	FB-61B	Fixed Base for MT-61A w/tilt over feature	TRUCK	169.95

NOTE:

On Coaxial and Rotor Cable, minimum order is 100 ft. and in 50' multiples. Prices and specifications subject to change without notice. Ninety Day Limited Warranty, All Products FOB Las Vegas, Nevada

PRICES EFFECTIVE FEBRUARY 1, 1980

Nevada Residents Add Sales Tax

Ship C.O.D. Check enclosed Charge to Visa M/C

Card # _____ Expires _____

Bank # _____ Signature _____

Please Print

Name _____ Phone _____

Street _____

City _____ State _____ Zip _____

Prices and specifications subject to change without notice.



Ham Gear Where You Find It

BY KARL THURBER, JR., W8FX

Many hams entered Amateur Radio by way of Citizens Band and know of the myriad goodies and gadgets made especially for the CBer. Many of those items can be useful in the hamshack. For hams who are unaware of the bonanza in special-purpose parts and products spawned by the growth of CB radio, here are some tips on some potentially useful additions to your station . . . additions that, because of the overproduction and overstocking of CB equipment to

meet a demand that never materialized, are often available for a song.

Transceiver aids

Many transceiver add-ons have been specially developed for CB use and sell for a fraction of the cost of equivalent Amateur units; this is mainly due to the high volume of production involved. SWR (standing wave ratio) bridges, rf power-output meters, field-strength meters (FSM), and TVI (television interference) filters are foremost among these devices. Don't hesitate to make use of these handy designed-for-CB

gadgets, as they will often do a good job for you. However, you must recognize that quality is sometimes lacking in the cheaper products. Also, most of the CB-type rf accessories are designed for use at relatively low power levels, normally not to exceed 100 or 200 watts. They are usually intended to work well up to about 30 MHz (just above the CB frequencies); most will not work properly on 2 meters or higher. I have found some CB SWR bridges for under \$10 that will handle a full "gallon" (1 kilowatt) input on 2 meters, but this is the exception, not the rule. You should find most of

these inexpensive products suitable for QRP or mobile operation on the high-frequency bands. As an example, my 10-meter QRP station (which uses a converted Johnson SSB CB set) uses CB accessories and components *entirely*, from power supply and transceiver to SWR bridge, antenna coupler, and antenna.

CB-type hardware of the type sold by Radio Shack, McGee Radio, Etco, Lafayette, Burstein-Applebee, and Olson (frequently at bargain-basement prices) has usefulness in most any shack. Such items as coaxial-cable assemblies and connectors, adapters of all kinds, microphone accessories, speaker plugs and jacks, filters, lightning arrestors, dummy loads and the like are often useful and cheap. I especially favor such handy goodies as the 100-watt, Olson #CB-661 power meter for \$7; the Olson #CB-391 SWR bridge that works to 144 MHz for all of \$11; shielded replacement coiled cords for microphones at 79¢; and the McGee quick-disconnect PL-259 adapter that instantly converts your mobile coax plug to an easy-off connector for \$1.79. And, I find that the two- and four-pin, inline power harnesses sold by Radio Shack and McGee are great for making quick-release power and speaker connections. In general, you will see that the pages of all these firms' sales catalogues and flyers are chock full of closeout bargains on connectors, wire, cable assem-



Inexpensive filters will help prevent TVI, and it's a good idea to use them, even with low-powered rigs. This unit has a cut-off frequency of 41 MHz, and attenuates harmonics in the TV channels by 25 dB or better.



This way to 10-meter fun. I use a converted Johnson CB rig in my car, in a standard under-dash mount, shown at the left. When I want to use it in the house, right, it slides into a similar mount under the unique power supply with its long legs that allow space for the rig. The power supply and mount combination will accept either a CB rig or my converted 10-meter unit. I've worked as far as England, Australia, and French Guiana with this 25-watt PEP rig.

blies, hardware, and other components manufactured for other purposes but which you can easily appropriate to fill your hamshack needs.

Mobile goodies

The greatest CB bonanza lies in the many items that can be adapted for Amateur mobile use. Some of the products you may want to look for when shopping your next CB "coffee-break," hamfest, discount store, catalogue showroom, CB supplier, or mail-order flyer would be CB-type extension speakers and paging horns; noise-cancelling replacement-type microphones (avoid the power-mike type); underdash transceiver mounts; mobile ignition system and alternator noise filters; spark-plug static shields; and replacement dc power-cord assemblies. Again, the pages of the mail-order catalogues and flyers are full of such goodies, usually at attractive prices.

I have purchased several sets of mobile underdash transceiver slide mounts and have mounted all of my mobile units on them — including a CB SSB

transceiver, a 2-meter fm radio, and a converted CB rig for 10-meter SSB. Having done this, I can swap gear between two automobiles and the shack workbench with ease. A handy power supply I use for this equipment is the Gold TI-8000 sold by Olson (obtained on sale for \$20). This unit stands on four high legs and has an underdash-type CB slide mount installed on its underside to accommodate your transceiver. This feature allows the set from your vehicle to be instantly inserted and either tested or placed on the air! Using this kind of arrangement, you may find that some of your mobile equipment can at least temporarily take the place of separate fixed station gear.

Antenna and antenna parts

Adapting CB antennas and antenna components for ham projects is pure fun. Many CB antennas, especially those of the mobile variety, are sold at attractive closeout and loss-leader prices. A mobile base-loaded or gutter-mount antenna can be purchased for as little as \$7 from some suppliers, and

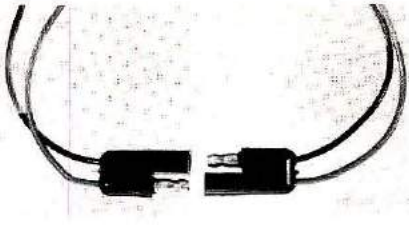

Polarized quick-disconnect plugs, made for CB rigs and audio equipment, allow you to make foolproof connections to your ham gear. For most versatile use of your rigs, install these plugs in your car, ham shack, and workshop.

it will work on ten meters with little modification other than clipping off an inch or so from its length and readjusting for resonance with the help of an SWR bridge. Most fixed-station CB antennas can be made to work well on ten with a minimum of modification; these often sport impressive gain figures over the basic quarter-wave antenna. Four- and eight-element beams are good buys, especially the cross-polarized kind. My favorite CB-to-ten base station antenna is the Radio Shack #21-965; it is a full 1/2-wave coaxial type vertical which provides good coverage and does not require the use of groundplane radials. It is fixed-tuned to the center of the CB band, and is of sturdy, marine-type glass-fiber construction. I find that this antenna performs nicely for me in 10-meter QRP work, even though it is not modified, when fed through a short length of RG-8/U coax to an antenna coupler. The coupler effectively tunes out the mismatch that the transceiver "sees."

Now is a good time to mention that the small, low-power, CB-type antenna tuner is just the ticket for precise antenna matching when using a CB antenna (base or mobile) on 10 meters. Almost all CB equipment manufacturers sell a "CB-matcher" or antenna-tuner accessory, which is frequently combined with an SWR bridge for one-stop measurement and adjustment. This is a great combination; my favorite unit (the one I use with the Radio

Shack vertical) is an Olson #CB-622 combination field strength meter, SWR bridge and antenna matcher. This \$32 list-price goodie was obtained on sale for all of \$10. An Olson two-position coaxial antenna switch (#CB-579, \$3), a CB-141 lightning arrester (\$2.50) and a CB-322 dummy load (\$2) complete this bare-bones QRP installation.

If you want to use both your CB set and your Amateur gear in your car (using, say, the



The inexpensive "CB Matcher" can be a handy device to use with 10-meter antennas made from CB beams or verticals. Radio Shack, Gold Line, Olson, Johnson, and others make a variety of low-cost units. Most are for low-power, however, so don't try to use one with a big amplifier.

lockmount arrangement) yet don't want to install two or more *separate* antennas on the car, run a *single* coaxial cable to the antenna mount. Use your present base-loaded CB antenna without modification for that band; use another interchangeable coil-and-whip assembly for 10 meters. Then, make a two-meter antenna by inserting a 50 cm (19 inch) whip into a PL-259 connector, filing down the center pin slightly so that it can touch the center pin on the mount when threaded onto it. What could be simpler for three-way mobile work?

You will undoubtedly find good use for much of the interesting antenna hardware made specially for CB: replacement mobile-mount assemblies of many different kinds, glass-fiber and stainless-steel whips,

replacement loading coils, springs, cable assemblies, mounting brackets, adapters, and the like all offer good potential for your antenna projects.

The CB set

In addition to CB parts and components, the transceivers themselves provide excellent possibilities for ham use. The easiest sets to convert are the hand-held portable units. In most cases, all that is required is to install a pair of crystals for the 10-meter band and realign the set . . . that's it! Almost any of them can be modified, but look for one that is clearly not a toy and that has at least two watts output for good results.

You can also convert "straight" and PLL (phase-lock-loop) 23- and 40-channel sets . . . QST and 73 Magazine both have published conversion articles. American Crystal Supply Co., P.O. Box 638, W. Yarmouth, Massachusetts 02673, makes complete conversion kits for more than three-hundred popular models of CB radios. You can install the kits yourself if you're handy with a soldering iron and a schematic. Bristol Electronics and Standard Communications also offer specially pre-converted



Extension speakers are useful everywhere and usually provide better audio quality in the car or shack than what you get out of most built-in speakers. The swivel base allows you to direct the sound as you like. Be sure they are rated for at least five watts and will match your transceiver's output (usually 4 or 8 ohms).

sets for Amateur use.

If you have a transceiver but do not have the technical knowledge or time to make a conversion, several firms offer custom conversion services for reasonable fees. Certified Communications, 4138 S. Ferris, Fremont, Minnesota 49412, can professionally convert almost any set for Amateur use for about \$55. The same firm also sells several models of con-



Most CB transceivers can be converted to 10 meters by changing a few components and doing a bit of realignment. Several firms offer conversion service if you don't feel up to doing it yourself. Amplitude-modulated (a-m) sets are frequently available for a song, but you'll find the SSB units much more useful, not only for 10 meters, but to work with converters on the vhf and uhf bands too.

verted Johnson SSB sets; I use a Johnson 4740 converted by this company, and find it to be a star performer, covering a good "40-channel chuck" of the 10-meter band from 28.050 to 28.945 MHz.

If you go the QRP conversion route to 10, in any case carefully consider whether it's worthwhile to convert your present set, especially if it's a-m. SSB is *the* way to go, despite the fact that a-m recently has seen a revival of interest on 10 meters. Also, a 40-channel set will enable you to cover a far wider band segment than will a converted 23-channel set.

Some you don't need

There are *some* CB accessories and products that are very cheaply designed, intended for a less-technical and sophisticated consumer market. Such items as "on-the-air" signs that illuminate from rectified rf from your transmitter, dummy loads that "light up," power microphones, cheap boom-microphone assemblies, and the like, do nothing for your signal and are best avoided. The same goes for such devices as modish but inefficient motorized CB automobile

antennas (which will work on 10 meters, but are not effective radiators). The same also goes for built-in windshield CB antennas, and special couplers which allow your regular auto or CB antenna to be used interchangeably on fm, a-m, and CB — its presence will certainly result in signal loss if you pump your ten- or two-meter rf through it, despite advertising hoopla to the contrary.

CB stuff is fun to buy and adapt for ham use, and you're likely to save some cash in the process. Nevertheless, it pays to select apparently bargain-priced CB components with special care; rarely are such goodies designed or intended for heavy-duty, high-power applications. Be judicious, but try some "CB stuff"; it could be just great for ham-radio use.

Shopping tips

For local sources of "converted" CB components and products, try your Radio Shack (especially their bargain table), Lafayette, Team, and other electronics chain stores. Look also at your local CB retailer and repair shop, where you may well find discarded parts and components that can be salvaged for Amateur use. Dis-

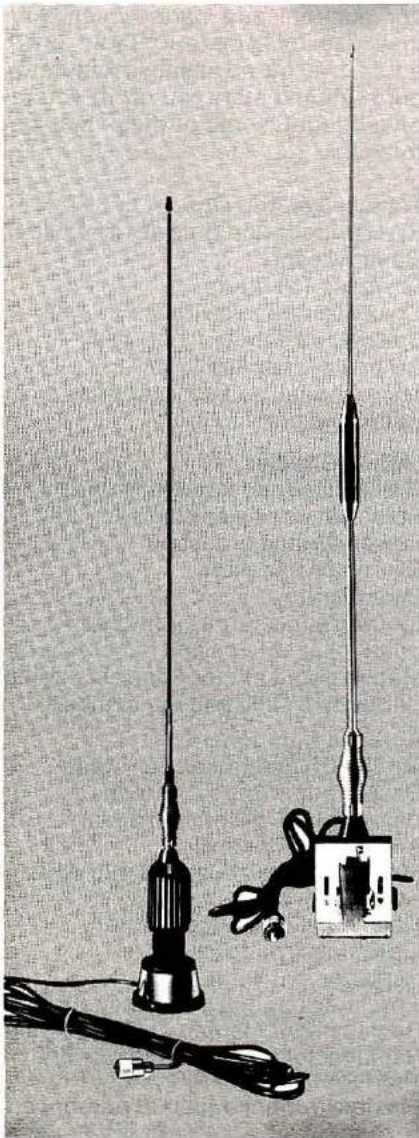

Mobile antennas are relatively easy to convert for 10-meter use. This Sparkomatic clip-on antenna (left) requires only slight shortening of the length above the center loading coil. For best mobile results, however, use a regular mobile-mount antenna such as that at right. The coil usually need not be touched, and the mount's good contact with the car body will help your signal get out.

When it comes to
**AMATEUR
RADIO QSL's...**

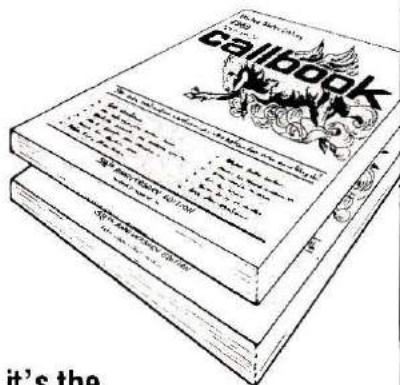

it's the
ONLY BOOK!
US or DX Listings

1980
callbooks
NOW READY!

Here they are! The latest editions. World-famous Radio Amateur Callbooks, the most respected and complete listing of radio amateurs. Lists calls, license classes, address information. Loaded with special features such as call changes, prefixes of the world, standard time charts, world-wide QSL bureaus and more. The new 1980 Radio Amateur Callbooks are available now. The U.S. Edition features over 400,000 listings, over 120,000 changes from last year. The Foreign Edition, over 315,000 listings, over 90,000 call changes. Place your order now.

	Each	Shipping	Total
<input type="checkbox"/> US Callbook	\$16.95	\$1.75	\$18.70
<input type="checkbox"/> Foreign Callbook	\$15.95	\$1.75	\$17.70

Order both books at the same time for \$34.65, includes shipping.

Order from your favorite electronics dealer or direct from the publisher. All direct orders add \$1.75 for shipping. Illinois residents add 5% Sales Tax.



SPECIAL LIMITED OFFER!
Amateur Radio
Emblem Patch
only \$2.50 postpaid

Pegasus on blue field, red lettering. 3" wide x 3" high. Great on jackets and caps. Sorry, no call letters.

ORDER TODAY!

RADIO AMATEUR
callbook INC.
Dept. EB 2
925 Sherwood Drive
Lake Bluff, IL 60044



Sometimes the hand-held CB transceivers are easiest to convert to 10-meter use; simply change the crystals and retune them. The larger units, such as this five-watt handheld from Radio Shack, are especially useful. Some have battery-saving low-power switch positions, and 1, 2, 6, or more channels. The cheap milliwatt-powered "toys" are usually not worth bothering with, however.

count and chain stores are also a possible source of supply.

Shop the mail-order houses. The following companies will send you catalogues upon request:

Olson Electronics, 260 S. Forge St., Akron, Ohio 44327

McGee Radio and Electronics Corp., 1901 McGee St., Kansas City, Missouri 64108

Etc Electronics, North Country Shopping Center, Rt. 9 North, Plattsburgh, New York 12901

Burstein-Applebee Co., 3199 Mercier St., Kansas City, Missouri 64111

Lafayette Radio-Electronics, 111 Jericho Turnpike, Syosset, New York 11791

Local hamfests, swap meets

and CB "coffeebreaks" also are good bets for obtaining new, used, and "junk" CB components and parts which you may be able to use.

Check recent catalogues to determine the availability of the specific examples of bargain-priced CB components I have mentioned. These were all obtained on sale, and sale prices vary considerably.

CB GOODIE CHART

Table 1. Here's a list of various CB components and parts which you may use for Amateur Radio projects. It is by no means complete, but it should start you off. If you're on a budget, some of these may be for you.

Transceiver Add-Ons

- SWR bridges and rf power meters
- Dummy loads
- Lowpass TVI filters
- Coaxial antenna switches
- Speaker switches
- AC power supplies
- Microphones and accessories
- Receiving preamplifiers

Mobile Goodies

- Quick-disconnect power plugs
- Polarized dc power-plug sets
- Power-wiring harnesses
- Extension speakers
- Pager horns
- Ignition and alternator filters
- Spark-plug shields and suppressors
- Mobile boom-microphone assemblies
- Underdash slide and hump mounts

Antenna Components

- Mobile CB antennas of all kinds
- Base-station vertical antennas
- Base-station directional beams
- Antenna tie-down clips
- Mobile-antenna dust and rain-cover caps
- Quick-disconnect connectors
- Lightning arrestors
- Replacement whips
- Antenna couplers and matchers
- Replacement loading coils
- Replacement antenna mounts and springs
- Flexible (rubber duck) CB antennas

Miscellaneous

- Transceiver carrying cases
- Cable assemblies
- Various connectors and adapters
- Spare fuse assortments
- Wire Cable
- Hardware
- 49-MHz gear (for 6-meter use)

HRH



Dear Horizons:

From the always striking cover page till the last one, variety is a priority, with subjects dealing with the past, present, and future.

Your magazine sure knows about the "line of horizon," and even above! Carry on the good work.

Victor Livernois, VE2NK
Quebec City, Canada

Dear Horizons:

How about some information on how to use the International Crystal kits.

I subscribe to *QST*, and *73*, but *Ham Radio Horizons* is the one for me. Keep your magazine educational as it is, don't let it become an electronics engineering magazine. I am only an Amateur.

Ramon Amoros, KA4HBI
Miramar, Florida

Dear Horizons:

The remotely controlled antenna switch (by Dave Malley, June, 1979, *Horizons*) was just what I needed, as I was about to put up monoband antennas for 10-, 15-, and 20.

I ran into one major problem. The 2.5 μ H (2.5-mH?) rf chokes in my junkbox had far too much resistance and created enough voltage drop so the switch wouldn't operate properly. The problem was solved with the help of W1VD, who suggested that I wind a couple of toroids. The final product used about 30 turns of No. 24 (0.5-mm) wire on an FT-50-72 core.

Everything is on the tower now, and, with 120 feet of coax, it's working fine.

Tom Frenaye, K1KI
Unionville, Connecticut

Dear Horizons:

After being inactive for many years, my first issue of *HRH* helped to get my interests back into ham radio. I enjoyed many of your fine articles that helped to "fill me in" with what was happening in ham radio today.

My only complaint is that you're going a bit too heavy on "The good old days," and fiction articles. How about more technical articles (with basic explanations) like your October, 1979, "Long Wire Antenna." These are excellent instructional articles.

Joe Szczech, K1IKE
East Haddam, Connecticut

Dear Horizons:

The article by Jon Lindsay, W6OIG, and his buddies in the October issue of *Ham Radio Horizons*, "DXpedition on Navassa Island," was great. The U.S. Navy sent operator MacQuiggan and me, in 1917, to report on ship movements in World War I. We used a spark set and reported in coded messages to Guantanamo Bay, Cuba. During our three-month stay on the island, we were quartered in one of the three houses at the landing dock. We climbed the upgrade pass to the lighthouse to visit the keeper and his family. They lived in a building near the lighthouse, now in ruins. The frequent rains kept their cistern full of water; the cistern was a large tank built in the cellar.

The kerosene lamps in the lighthouse were turned by weights which were cranked up daily, like a cuckoo clock. We would climb the circular stairway to the top where we could see the whole island as well as the herds of goats.

The rails that were used by the guano factory were still there, also several tram cars. The guano was nothing more than the droppings of the thousands of frigate birds. You could hear the tree limbs breaking from the weight of roosting birds. The article reminded me of the time when I was twenty years old as a radio operator on Navassa Island.

John F. Coleman
Ft. Lauderdale, Florida

Dear Horizons:

I would like to congratulate you on *HRH*. It's a great magazine for old timer and Novice alike!

I thought that you might be interested in using the enclosed photo of my newly licensed eleven-year-old son Ken, KA5EFE. I'm sure that Ken is far from the youngest, but other youngsters may be encouraged by one more young ham. Ken received his novice ticket in March, and he is now working on increasing his code speed and earning his WAS certificate.

Thanks again for a fine Amateur publication!

Bob Jones, W5TU
Garland, Texas



Dear Horizons:

I've had my General class license for three or four months now, and have come across a wierd noise on 15 meters. It seems to stick mainly in the phone bands, and is quite an irritating noise. It sounds like a helicopter, or a piece of wood being slapped on the ground.

I'd like to know what it is.

Mark Elledge, KA6ALK
Los Gatos, California

That's the notorious "Russian woodpecker" noise which everyone has been complaining about. Guesses about its purpose range from "over-the-horizon" radar to ionospheric heating and weather control. The Russians are not talking about it.

Editor

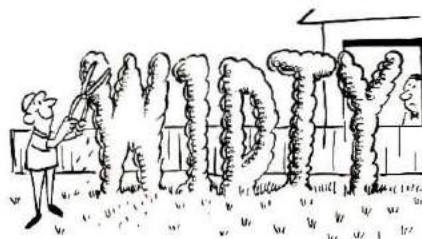

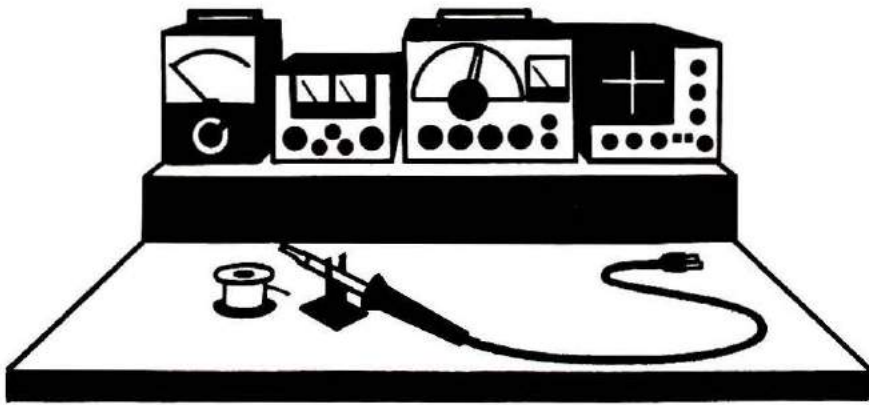

BENCHMARKS

Yagi Antenna For UHF — Simplified Construction

Homebrewing antennas has never been one of my strong points. Most of my beams had more of an omnidirectional characteristic than a main lobe. The problem was making all the elements point in the same direction. If your main construction tools are the same as mine — a blow torch and a sledge hammer — then the techniques I managed to acquire may be helpful in making your next beam look more like an antenna than a corkscrew.

Drilling holes is probably the

most critical part of construction. I used a drill stand to hold the drill in place. I made a guide from a piece of V-channel aluminum bolted to a piece of wood (see Fig. 1). The V block keeps the tubing from wandering during drilling. Be sure the drill is centered in both directions in the stand. Use a scrap piece of tubing to drill a test hole, then insert an antenna element to

check for alignment. It took me three tries to get the drill oriented just right.

The next problem was how to hold the elements in the boom without using a lot of clamps or brackets. After many tries, I used speed nuts. They worked well and held the elements firmly in place. I pressed a speed nut onto each element end (Fig. 2). Caution: When pushing the speed nuts up to the boom, be certain that the element is centered (Fig. 3), because backing up the speed nuts is nearly impossible. Speed nuts are available in many sizes at most hardware stores. I applied a liberal coat of silicone rubber to protect the speed nuts from rust (Fig. 4).

After the first element is mounted, it's used to align the other holes as you look down the boom. The drill bit acts as a gunsight for alignment (Fig. 5). If

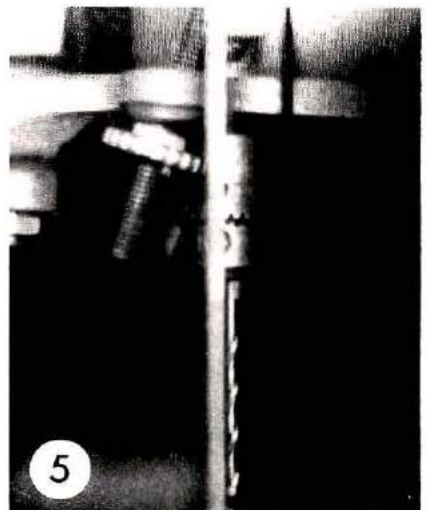
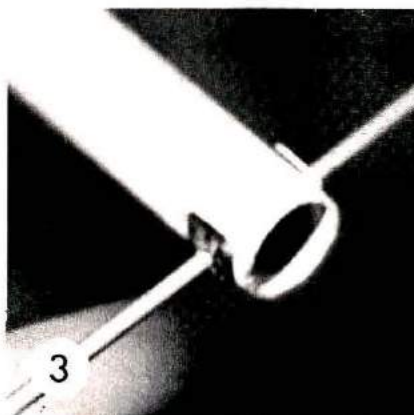
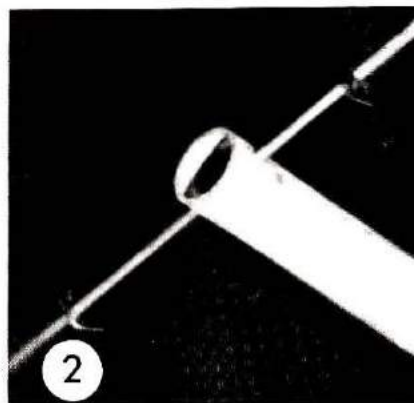
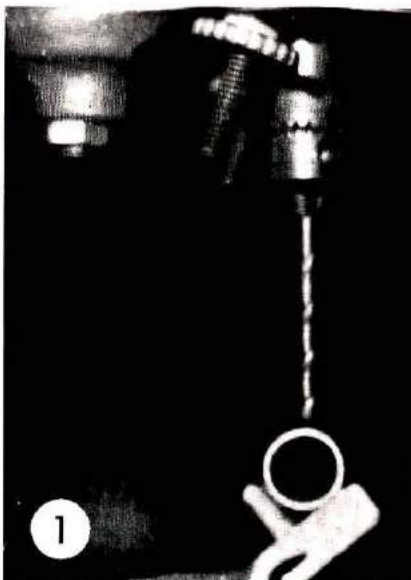

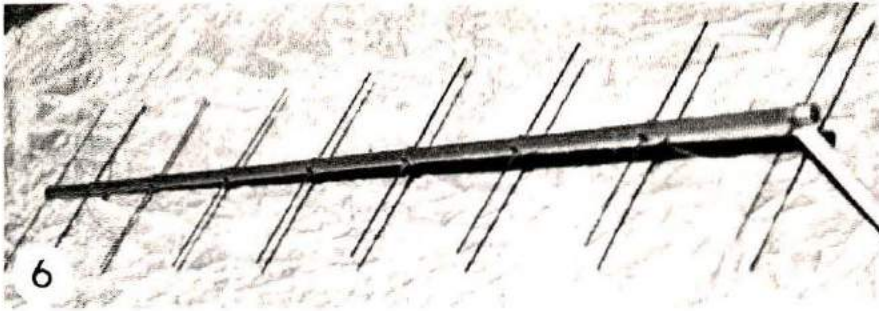

minor misalignment exists, correction can be made by forming the elements.

The antenna shown in Fig. 6 was my first attempt to build a 432-MHz Yagi using the method described. The cost was just over \$5.00, using an aluminum boom and welding rods for ele-

ments. I've also built some 2-meter Yagis. Tests have shown that these homebrew antennas are within 1/2 dB of their commercial counterparts. Pattern checks have shown a clean main lobe.

Thomas Varnecky, WA3CPH

Metal Cleaning With Dip-Type Cleaners

Those who have occasion to clean brass, copper, silver, or gold may take advantage of some of the chemical cleaners that quickly strip surface oxidation. Numerous brand names are available. One is "e-z-est Jeweler for Coins," formula H-907, from Products Research Company, Box 11115, Oakland, California 94611. Chemical dip cleaners can be obtained at coin dealers, silverware departments of larger department stores, and at some supermarkets. I purchased 142 grams (5 oz.) of the above product at a coin shop for about \$2.

Either dipping the object into the liquid, or brushing it on in the case of larger surfaces, quickly strips surface oxides leaving the metal bright and shiny. It can then be soldered easily, or sprayed with protective acrylic varnish to prevent tarnishing. Take care in cleaning plated objects, however. Leaving the chemical on the metal too long will result in some surface metal loss. If in doubt, test a small area first. After cleaning, rinse the object thoroughly in running water to stop the chemical etching action.

Chemical composition may vary. However the active ingredient in the product mentioned is thiourea, $CS(NH_2)_2$, a chemical bleaching agent used in photography. Where large applications would make cost an important factor, it may be worthwhile to purchase thiourea from a chemical supply house. Above all, follow the manufacturer's instructions carefully.

Robert Wheaton, W5XW

Tailoring Audio Response

This is an old idea with merit, but I've not seen it in print for some time. Listening to the receiver hiss during long periods of reception can be tiring. The audio response of a low-impedance speaker or phones may be tailored by adding an electrolytic capacitor of about 50 μ F across the receiver speaker terminals or audio output jack. This will limit the audio high-frequency response and thus the hiss, making both CW and SSB reception more pleasant. Some overall attenuation will occur, but it is relatively minor and can be compensated for by increasing the audio gain.

Paul K. Pagel, N1FB

Shirt-pocket Code-practice Oscillator

How many of you out there have been bitten by the ham radio bug? If you have, one of the first things you quickly learn is that you must master the Morse code to obtain any type of Amateur Radio license.

Here is a cheap and easy transistor-radio modification that will get you started on the road to becoming an Amateur Radio operator. You will need one inexpensive transistor radio; two 12-inch pieces of hook-up wire; and a telegraph key.

To modify the set:

Step 1. Remove the back cover of the radio and locate the speaker-terminal wires.

Step 2. Locate the volume control and note the three solder lugs coming from the control to the printed circuit board. Some radios may require the removal of the circuit board from the case in order to expose the volume control.

Step 3. Turn the radio on at half volume, and tune it away from any station.

Step 4. Prepare the two 12-inch pieces of hook-up wire by removing 1/8-inch insulation from both ends of the wires.

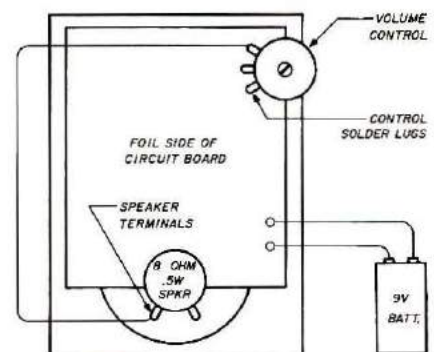

Fig. 1. After you have located the speaker terminals and the solder lugs, or connections on the volume control, use a jumper wire to find out which combination will cause an audible squeal or howl.

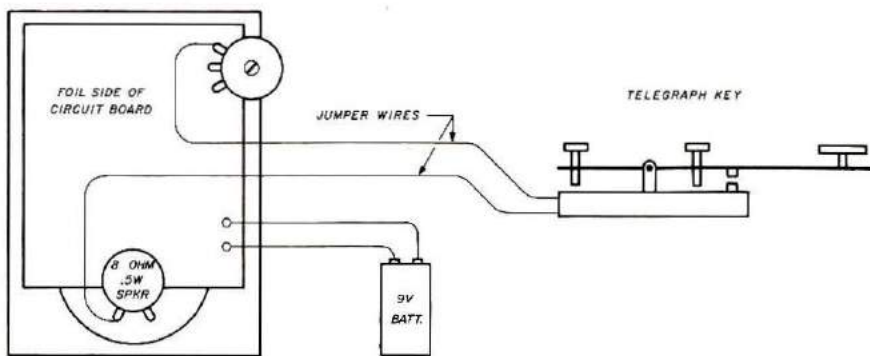

Fig. 2. Solder the ends of the jumper wires to the points that cause a squeal, as found in Fig. 1, and connect the other ends to your telegraph key. You're ready to practice sending Morse code. When the key is open, or disconnected, you can still tune in your favorite station just as before.

Step 5. Take one of the prepared wires and touch one end of it to one of the speaker terminals and touch the other end to one of the volume control lugs. (See Fig. 1.)

Step 6. You should hear an audio tone, ranging from a low buzz to a high-pitched squeal. If not, touch another one of the lugs from the control with the jumper wire used in step 5, and repeat step 5 again.

Final Product and Assembly: Once you have determined the points of best operation by using the jumper wire, solder one of the 12-inch hook-up wires to the volume control and the other 12-inch wire to the speaker terminal. Bring these two wires out of the radio case and connect them to your telegraph key. (See Fig. 2.)

You will be pleased to find that both the pitch and volume can be changed by turning the volume control up and down. You will also notice that you can still enjoy your favorite radio station when you finish with your code practice, as this modification does not impair normal operation of the radio.

How it works: The theory of operation is based on audio feedback, which is accomplished in this case by injecting part of the audio output (from the speaker) into the audio input, thus causing an audio oscillation. This works in the same way as the audio feedback that many of you have witnessed when someone using a public address microphone steps too close to the loudspeaker, with the results being a loud squeal.

I know you will be proud of your first Amateur Radio project, and I hope that it will give you confidence to dive head first into the scientific hobby of Amateur Radio.

Harry W. Pardue, AA4AG/5

I would like to see . . . the FCC enforce the rules I worked so hard to learn!

John Ash, WD6BNH



Tri-Ex's "L'il Giant", A Tower For All Reasons.

MODEL NO. ED40 **\$595**

Like a legendary character of yesteryear, the new TRI-EX "L'IL GIANT" is destined to become a modern-day Superstar among crank-up towers that is its strong, durable, yet lightweight.

Four 12 foot (3.6m) sections, each with a solid 2 1/2 foot (.76m) telescoping overlap for added strength. Cranks up securely and effortlessly to heights of up to 40 feet (12m).

Now available from your TRI-EX dealer, the "L'IL GIANT" is truly versatile. Use it for 2-way radio, Ham radio, CB, TV, FM, etc.

Here are some of the reasons why "L'IL GIANT" is headed for stardom:

- Compact — Only 13' (4m) when nested
- Made of TRIEXIUM™ — TRI-EX Tower's exclusive space-age metal alloy it's non-corroding and maintenance-free (never needs painting)
- Lightweight — Only 77 lbs. (35kg) including winch
- Strong — Holds 6 sq. ft. (56m²) antenna load in 50 mph (80kph) wind. Carries 50 lbs. (23kg) dead load
- Square Tubing Design — Minimizes tower twisting, stabilizes antenna direction
- Easily Erected — Usually can be put up by one person in 1/2 hour or less
- Hinged Base — Allows easy push up to vertical position.
- Safety Winch — Will not free spin. When retracting, tower must be cranked down
- Stainless Steel Hoisting Cable
- Will conform to Electronic Industries Association Standards
- Price Is Complete. Includes Guying Kit

See your dealer or call
TRI-EX for name of nearest
dealer 209-625-9400

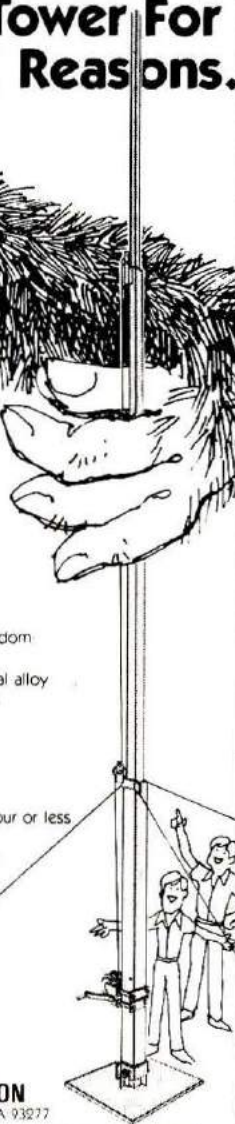



Tri-Ex®
TOWER CORPORATION
7182 Reasmussen Ave., Visalia, CA 93277

PRODUCT SHOWCASE

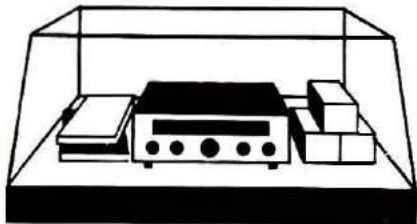

For literature on any of the Product Showcase items use our ad-check service on page 78.

Kantronics General Combo

Kantronics' General Combo is a complete, carefully organized program for the Amateur who wants to upgrade.

The *General-Class Amateur-License Study Guide*, SAMS No. 21617, by W0XI, explains radio circuits in an easy to understand style. The primary purpose of the text is to assist the Amateur in obtaining the General-class license.

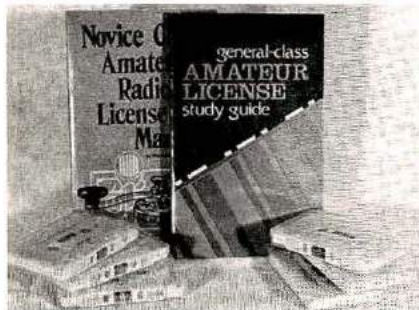

A second purpose of the text is to provide not only memorizable information for the exam, but also usable knowledge on electronics and practical radio circuits. The author's point of view is that an understanding of the material can then lead to a later, more-detailed study of electronics, and to a greater enjoyment of our hobby.

Each chapter begins with introductory material and builds on this material to form more general concepts. The text explains the test, Amateur regula-

tions, radio-wave propagation, practical radio circuits, modulation characteristics, and transmission lines. Throughout each chapter, sample exam questions test your understanding of the material, and prepare you for the FCC exam.

The *General Cassette Tapes* discuss rules, regulations, and radio theory in an interview format. The *QSO Tape* simulates exam-like "on-the-air" code transmissions. It progresses from 7½ to 15 WPM. A text key and practice exams are included, which test your proficiency in copying the *contact* of the message, and prepare you for the new FCC code-test format.

Suggested Combo price is \$19.95, from Kantronics Inc., 1202 E. 23rd Street, Lawrence, Kansas 66004; (913) 842-7745.

Portable Emergency Antenna

Larsen Electronics, Inc., has a portable emergency antenna that requires no ground plane and is compact enough to fit into your pocket. The PHW-150 loaded half-wave antenna covers the 144-174 MHz band. It features a stainless-steel flexible radiator that allows the PHW-150 to be rolled up into a convenient portable size.

To operate the PHW simply connect it to a portable radio with any length of coaxial cable, attach a length of fishing line to the antenna eyelet and a weight to the other end of the line, then



heave the weight over a tree limb and hoist the PHW-150 into the air with the fishing line.

Having Larsen's PHW-150 is like having a base antenna and tower in one compact portable unit. The PHW-150 can provide as much as 20 dB gain when compared to a portable radio's normal antenna.

The PHW-150 comes without fishline, weight and coaxial cable. For more information write John Beaman, Larsen Electronics, Inc., P.O. Box 1686, Vancouver, Washington 98663.

Avanti High-Performance Glass-Mounted Antenna

One of the most successful pioneers in antenna design and engineering — Avanti Research and Development, Inc., of Addison, Illinois — has just introduced a new 3-dB gain, high-performance mobile antenna that's specially designed for Amateur Radio operators.

It's called the AH 151.3G, a 2-meter antenna (tunable to 174 MHz), that features a sleek, low-contour design and provides improved vhf signals. Also has a half-wavelength design that's guaranteed to deliver superior performance over a deck-mounted 5/8-wavelength antenna. It transmits a more uniform pattern than a typical "ground plane" antenna.

A unique on-glass mounting design eliminates the need for external electrical connections — thus preventing coax cable deterioration caused by corrosion and water seepage.

The patented "High-Q" impedance coupling unit, with built-in Ritter noise reduction system, mounts inside the vehicle to ensure maximum performance throughout the 2-meter band. There are no holes to drill, no car-body patching at resale time.

A new aerospace adhesive discovery securely locks antenna mount to glass with the strength of a 1/4-inch bolt, yet

it can be removed instantly for storage, car wash, or theft protection. The mount is guaranteed to hold securely under even abnormal weather conditions and excessive vibrations. Durability is also ensured by triple-chrome-plated contour mount and 180 degree tilt-angle-adjustable whip holder. The whip itself is made of 17-7 pH stainless steel.

In addition to the AH 151.3G, Avanti makes on-glass antennas for Amateur Radio operators in the 220-225 MHz and 440-450 MHz bands, and trunk-mounted mobile antennas for comparative frequencies at 144-148 MHz and 440-450 MHz. Avanti also offers, especially for Amateurs, a 10-meter dual-polarity beam (AH028.98), which is the original polarity-diversity loop antenna.

For more information, contact Avanti Research and Development, Inc., 340 Stewart Avenue, Addison, Illinois 60101.

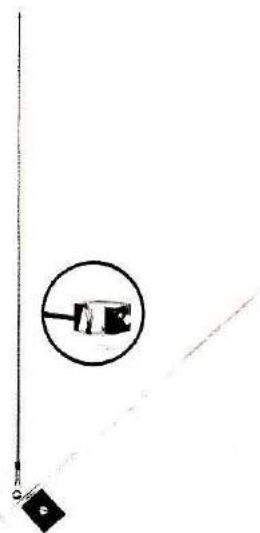

New MFJ Catalog

The new MFJ Amateur Radio Catalog for 1980 is available free from MFJ Enterprises, Inc., the nation's leading manufacturer of Amateur Radio accessories.

The products included are antenna tuners (from 200 watts to 3 kW); SSB and CW filters (from \$29.95 to \$79.95); memory keyers (3 models, \$79.95 to \$139.95); electronic keyers (from \$39.95 to

\$69.95); speech processors, rf noise bridge, frequency standard, code practice oscillator, and QRP transmitter.

This new catalog has 12 pages of photographs, descriptions, specifications, and prices of Amateur Radio accessories manufactured by MFJ Enterprises, Inc.

The catalog is free, and available by writing to MFJ Enterprises, Inc., P.O. Box 494, Mississippi State, Mississippi 39762.

Computer Logging Package

Snow Micro Systems, Inc., announces a logging package for Radio Amateurs. This package, written in Northstar BASIC, allows Amateurs to keep their log records on floppy discs.

The log data-file can be examined, edited, and printouts and summaries obtained of sections of the log. The entries can be listed by prefix such as G, G3, G3Z, G3ZC, or G3ZCZ. QSL card information can be automatically printed out by the computer.

Different logs can be edited, merged, deleted, renamed, searched, and summaries listed on any of the seven output devices supported by the Northstar system.

The package contains one disc, which includes sample logs and full instructions, and is available for \$15.00, postage paid.

For further information, write to Snow Micro Systems, Inc., P.O. Box 1704, Silver Spring, Maryland; or telephone (301) 622-1931.

Radio Shack General-Coverage Receiver

Now available from Radio Shack is a new general-coverage communications receiver that puts the world at your fingertips by letting you listen to short-wave radio broadcasts, as well as Amateur Radio operators, CB-

ers, aircraft weather stations, maritime broadcasts, and more.

Shortwave listening opens up a new world of entertainment for



you, and it can be educational as well as entertaining. News programs from other countries provide the listener with different perspectives on world events, and it is possible to learn about the customs, culture, music, and languages of other nations through short-wave listening.

The Realistic DX-300 general-coverage communications receiver features LED (light emitting diode) digital frequency display that makes it easy to tune to a specific frequency, or return to it whenever you wish.

Quartz-synthesized circuitry provides extremely stable, virtually drift-free reception as well as highly accurate tuning. A six-band preselector with built-in six-element ceramic filter and a three-position audio-bandwidth control sharpens selectivity and reduces signal interference.

The receiver tunes from 10 kHz to 30 MHz, and can receive a-m, upper and lower sideband, and CW (code). It operates from 120 Vac, 12 Vdc, or from eight self-contained "C" cells. A dial light/battery switch reduces battery drain during portable operation, and also indicates battery condition on the Signal-Strength/Battery meter.

Other features include a three-step rf attenuator to prevent overloading, rf gain control, built-in speaker, headphone jack, and a key jack for the built-in code practice oscillator. The heavy-duty cabinet has a recessed carrying handle.

The Realistic DX-300 general coverage communications receiver is priced at \$379.95. It's available from participating Radio Shack stores and dealers nationwide.

Memory Keyer

Announcing Con-puter 1, the totally new type of memory keyer for Amateur Radio CW contests or casual operation. Con-puter 1 permits the operator to store contest exchange messages which contain serial numbers. Such exchanges are required in the Sweepstakes, WAE, VK/ZL, and many other CW contests.

After initial storing of desired contest messages by the operator, Con-puter 1 automatically inserts the correct serial number. This number is also displayed. Each time the message is initiated, the serial number automatically increases by one, and the complete message, with number, is sent without further attention from the operator. Numbers up to 9999 can be accommodated.

Con-puter 1 also contains a leading-zero option which, when activated, automatically places zeros in front of numbers less than 100. The memory and address locations are digitally displayed for loading convenience. Con-puter 1's front panel has been kept simple for operating ease. It operates like a regular memory keyer when the serial number feature is not needed. Approximately two hundred characters may be stored in the four primary and four secondary message locations. The keyer has built-in sidetone and speaker. Either a regular or iambic key paddle may be used. Continuously adjustable keying speed is 5-60 WPM. Power requirements are 120-volt ac, 60 Hz, or 12-volt dc. Memory contents may be protected against power loss by connecting an external battery to terminals provided for that purpose on the rear panel.

The heavy duty aluminum cabinet measures 30 x 9 x 25 cm (12 x 3½ x 10 inches). Price is \$379 fully assembled, shipped prepaid and guaranteed. The operator's manual may be purchased separately. For more information contact Con-puter 1, 3006 Lockheed, Midland, Texas 79701.

RF Preselector/Preamplifier

If you are missing out on those weak DX signals because your receiver needs more sensitivity, here's a low-cost way to pep it up: Add the new Mizuho SX-59 Preselector/Preamp from Gilfer.

The SX-59 adds 20 dB of gain (3 or 4 S-units) with low noise. Tunable in three switched bands from 3 to 30 MHz, the unit is completely automatic in antenna switching — turn it on and it connects itself to the antenna, turn it off and the antenna is reconnected to the receiver; no manual bypass is needed.

Beautifully styled in a solidly made, beige-colored cabinet, the SX-59 has a built-in, switchable, 20-dB rf attenuator to cope with excessively strong signals, plus a range switch, rf-gain control, tuning dial, LED "on" indicator, coaxial input and output antenna connectors, remote-control terminals, and built-in power supply for 117Vac.

It's easy to use; just select the band and tweak the tuning dial for maximum signal. You'll be surprised at what you have been missing. And, if you have an old single-conversion receiver, the SX-59 will also reduce those images by 4 or 5 S-units.

Best of all, it's priced under \$100.

For complete information, write Gilfer, Box 239, Park Ridge, New Jersey 07656.



Hy-Gain Hy-Bander Antennas

Hy-Gain is offering two new 2-meter mobile antennas: the

Model 286, a trunk-lip mount, and the Model 287, which is on a magnetic mount. Both models have a ratchet-foldover feature that will adjust to a 180-degree arc. The ratchet will hold its whip position even at 150 mph. Hy-Gain's use of a printed-circuit loading coil ensures excellent tuning accuracy for low VSWR. The PC board technology provides up to 50 per cent more surface area for improved conductivity and heat dissipation. Standard features of both antennas include broad bandwidth, less than 2:1 VSWR from 140-152 MHz; less than 1.4:1 VSWR 144-148 MHz; power rated to 150 watts; 5/8-wave, 3 dB gain; ground for static protection; and 120-mph rating on the magnetic mount.

Along with the quality of these antennas, their pricing makes them the most competitive 2-meter mobile units on the market. The Model 286 trunk-lip mount retails for \$15.95. The Model 287 magnetic mount retails for \$19.95. Truly a quality antenna for the price. Write Hy-Gain Electronics, 8601 Northeast Highway, Lincoln, Nebraska 68505; or see your local dealer.

Hustler Ten-Meter Yagi

A new beam, designated 10-MB-4, is the result of extensive antenna design refinements by Hustler. The beam is a four-element Yagi optimized for best directivity, excellent front-to-back ratio, maximum gain through selective element spacing, and precisely resonated element lengths. The 10-MB-4 has a gamma-match feed system and is adjustable for a 1.2:1, or better, SWR.

The Hustler 10-MB-4 is designed to withstand severe weather, yet it's light enough to be turned by a TV antenna rotator. The entire antenna is built from high-strength aluminum tubing and can be easily grounded for lightning protection.

The new Hustler 10-MB-4 10-meter beam has a suggested list

price of \$109.95 and is available now. For further information on this or other Hustler Amateur antennas, write Hustler Inc., 3275 North B Avenue, Kissimmee, Florida 32741.

2-Meter Amplifier Kit

SST Electronics has added a 2-meter amplifier kit to their line

of Amateur Radio equipment. The SST A-1 amplifier kit provides 15 watts of output with 1 watt in.

The SST A-1 includes everything necessary for a complete amplifier. A drilled G-10 epoxy solder-plated PC board, 51 x 76 mm (2 x 3 inches), makes assembly easy (approximately one-half hour) with the com-

prehensive instructions. A large heat sink keeps the TRW power transistor cool. For ease of assembly, the coils used in the SST A-1 are prewound.

The SST A-1 is short- and open-circuit protected — not damaged by high SWR. Top quality components are used throughout. It is compatible with all 1-3 watt 2-meter transceivers. The SST A-1 sells for \$29.95 in kit form (\$49.95 wired and tested). Instructions are included for a carrier operated relay.

All SST products carry a 1-year unconditional guarantee and may be returned within ten days for a full refund if you're not satisfied for any reason. To order, call (213) 376-5887 or mail to SST Electronics, P.O. Box 1, Lawndale, California 90260.

General Class License Package

Selected with an eye towards quality and clarity, anyone looking to upgrade should get our new General Class License Package. The heart of this complete study course is Ameco's Amateur Radio Theory Course. It covers step-by-step the theory needed to pass probably the most important of all Amateur exams. For checking purposes you get the ARRL's brand new General Q & A. And to make sure you understand fully all the test material prior to sitting for the exam, Phil Anderson's new General Class Amateur License Study Guide is also included. Then to supplement your on-the-air code practice, we've included a diversified selection of cassette tapes from our very popular Integrated Code Training System. When purchased individually this is a \$29.80 package. Order this super training course NOW and SAVE \$5.85! Only from Ham Radio's Bookstore.



HR-GTP2

\$23.95

Ameco Amateur Radio Theory Course	\$ 5.95
ARRL General Q & A	2.50
Anderson's General Class Amateur License Guide	6.50
HR-STC-1 Straight Code Tape	4.95
HR-HLC3 Hi/Low Code Tape	4.95
HR-QS01 QSO Code Tape	4.95
	<hr/>
	\$29.80
	Value

Order Today

**HAM RADIO'S
BOOKSTORE**

Greenville, NH 03048

or Call Toll Free

1 (800) 258-5353

Wilson WV-1 Vertical Trap Antenna

No bandswitching is necessary with the new WV-1 Antenna. It's an excellent, low-cost, 10-40 meter vertical that offers an electrical quarter wavelength and a low angle of radiation. Advance design assures a low swr on each band. Large diameter, high-Q traps will maintain resonance with varying temperatures and humidity. A hot-dipped, galvanized, base-mount bracket and a full radial kit is supplied with each WV-1.

For more information, see your favorite dealer, or contact Wilson Systems, Incorporated, Consumer Products Division, 4286 So. Polaris, Las Vegas, Nevada 89103.

Carrier-Operated Relay and Identifier

Maggiore Electronic Laboratory offers a fully adjustable COR and Identifier board designed to mate easily with any repeater system. High-quality components are used throughout, and the mechanical design makes adjustment and programming easily done in the field.

Known as the Hi Pro COR-Identifier, the board features the usual high and low inputs to the COR as well as another input that can be connected directly to the squelch noise amplifier. The board includes LED outputs to monitor the COR timer and ID. The ID LED blinks in unison with the code program. Plugs on the board allow for easy installation and removal.

Unique to the Hi Pro board are provisions for installing a switch to control COR timer reset on either input or output, or to disable the timer so that the repeater can operate without timing out. This action is accomplished with one center-off spdt switch. Another feature provides for a switch that will allow either all or partial scanning of the diode matrix.

CMOS logic is used, which can be operated from 8 to 16 Vdc with very low current drain — something to think about when operating on emergency power.

Potentiometers are used liberally for ease of adjustment — no need to juggle components to get the right setting. Wide spacing of diodes on the matrix makes it easy to program and re-program in the field, with less chance of solder bridges and short circuits.

All this, plus the normal control functions associated with a COR and identifier, come completely assembled at the introductory price of only \$79.95. For more information contact Maggiore Electronic Laboratory, 845 Westtown Road, West Chester, Pennsylvania 19380.

New Larsen Amateur Antenna Catalog

Larsen Electronics, Inc., one of the nation's leading mobile-antenna manufacturers, has just published a new catalog for its complete line of Kulrod (R) Amateur antennas.

In addition to mobile antennas, this 12-page brochure also includes base station antennas,

Yagis, and antennas for hand-held and portable two-way radios. Available models cover the complete range of Amateur frequencies in the low, vhf, and uhf bands.

The catalog is conveniently arranged with antennas and corresponding mounts on the same page, so it's easy to order the right combination. There is also a complete price list for all equipment.

Copies of the Larsen Amateur Antenna Catalog are available at no charge from any Larsen dealer. They may also be obtained by writing to Larsen Electronics, attention John Beaman, P.O. Box 1686, Vancouver, Washington 98663.

New RCA MRO Semiconductor Replacement Guide

A new booklet listing most of the Semiconductor devices available for MRO (maintenance and repair operations) of industrial and electronic equipment has been announced by RCA's Distributor and Special Products Division, Deptford, New Jersey.

The identical replacement transistors, and other solid-state devices listed in the booklet are



available from distributors of RCA SK series. The MRO Industrial/Commercial Replacement Semiconductor Catalog/Data Booklet (1K5817) is available from RCA SK-Series distributors, or orders can be sent to SK Series Merchandising, RCA Distributor and Special Products, P.O. Box 100, Deptford, New Jersey 08096, with check or money order for \$1.00 per copy.

Curtis Keyer Uses Optoisolators

An advanced-design electronic keyer, with opto-isolators for isolation, has been introduced by Curtis Electro Devices, Inc. Based on the popular 8044 single chip circuit, the EK-480M also features a direct meter indication of code speed in WPM.



The unit contains all the features expected on a top-of-the-line keyer, including dot and dash memories, iambic or standard mode operation, internal 117 Vac or battery supply, internal sidetone and speaker, front-panel volume, pitch, weight, and speed controls, plus an accessory socket for a soon-to-be announced message memory. INSTRUCTO-KEYER and keyboard-keyer add-on units. The EK-480M will key + or - 300 Vdc at up to 200 mA.

Supplied complete with all cables and plugs, the EK-480M is priced at \$149.95. The EK-480 (without speedmeter) is priced at \$134.95. Both units are available now, either direct or through selected dealers.

For additional information, contact Curtis Electro Devices, Inc., Box 4090, Mountain View, California 94040.

Lafayette 6-Band Communications Receiver

Lafayette Radio Electronics Corporation has introduced the BCR-101 — a new 6-band communications receiver with a wide range of features. The unit, which retails for \$249.99, receives international and local shortwave, marine, amateur, CB, and a-m broadcasts.

Features of the BCR-101 include drum-type tuning dial with separate calibrated band-spread tuning on three bands; 50/500 kHz marker tone (crystal calibrator circuit); variable band width;

adjustable noise blanker; built-in front-mounted speaker; tracking control, and dual conversion for maximum sensitivity across each band.

The BCR-101 is ideal for power and sailboat operators, amateur, shortwave, and CB radio enthusiasts, and individuals interested in overseas broadcasts. The receiver is available through any of the more than 400 Lafayette stores and dealers in the U.S. or by mail order. For complete information on the BCR-101, see your nearest Lafayette dealer, or write Lafayette Radio Electronics Corporation, 111 Jericho Turnpike, Syosset, New York 11791.

Solar Energy Systems by Sem Con, Inc.

Sem Con, Inc., of Palos Verdes, California, has a series of solar-powered "Charge Boxes" and panels that provide power for portable, battery-operated Amateur and hobby equipment. The units need only to be connected to the equipment or battery and placed in the sun to begin providing "free" energy.

The "Charge Box" is a package of eighteen solar cells wired in series to provide either 9 or 6 volts at 125 mA. There is space inside the box for rechargeable batteries, and leads to connect to external equipment. A switch selects either 6 or 9 volts, and a built-in meter shows the charging level.

Also available is a 9-volt panel, with or without a stand, that provides 9 volts of charging current at 125 mA. A cord is provided for connection to radios or other equipment needing 9-volt power.

A similar panel, but without a stand, provides 6 volts at 125 mA, and has a connecting cord for radios or tape players that require operating voltage in this range.

Price for the Charge Box is \$79.95; for the 9-volt panel, \$59.95; and for the 6-volt panel, \$49.95.

Sem Con, Inc., also offers an a-m broadcast radio with its power-providing solar cells built into the cabinet for "energy-free" listening anywhere there is sufficient sunlight or artificial light. It also has an internal battery for power where there is a low light-level.

For more information, write Sem Con, Inc., P.O. Box 2751, Palos Verdes Peninsula, California 90274.

New Mobile HF-band Antenna

Anteck, Inc., of Hansen, Idaho, has just introduced a new antenna for the mobile high-frequency enthusiast. It's called the MT-1,



CDE antenna rotors

Two new high-performance antenna rotor systems, the Ham IV™ and the CD-45, have been introduced by Cornell-Dubilier Electric Corporation of Newark, New Jersey.

The new Ham IV is designed for large communication antenna arrays of up to 15.0 square feet wind load area, tower mounted. Highlights of the Ham IV include power braking, machined steel drive gears, dual transformer circuitry, and other design features to make it the choice of serious communicators.

The new CD-45 accommodates antenna arrays of up to 8.5 square feet wind load area, tower mounted, and features a professionally styled control unit, illuminated metered read-out, all-steel drive components and automatic disc braking.

Both the Ham IV and the CD-45 operate at safe, low-voltage control levels, with reliable snap-action rotational controls for accurate, trouble-free operation. For more information, write Leonard Sabal, Cornell-Dubilier Electric Corporation, subsidiary of Federal Pacific Electric Company, 150 Avenue L, Newark, New Jersey 07101.

and will tune from 3.5 to 30 MHz, inclusive. This continuous-tuning feature allows it to be used for such nonamateur uses as MARS, CAP, Maritime, and CB simply by adjusting it for the correct frequency.

The MT-1 is rated to withstand 750 watts PEP. It is adjustable from the base for ease of tuning, and you can adjust it to the precise frequency you want, which means that the swr-shutdown of solid-state rigs is avoided; you can use them to their full output.

A stainless-steel whip, fiberglass loading coil, and beryllium copper contacts assure long-life and trouble-free operation. It is unaffected by moisture, and comes in an attractive blue and gray finish. The MT-1 is priced at \$119.95. For more descriptive literature, write to Anteck, Inc., Box 415, Route 1, Hansen, Idaho 83334.

Invisible 10-Meter Mobile Antenna

The "Ten/Tenna," for 10-meter and CB use, mounts inside metal-roofed vehicles and excites the car shell into radiation as a 10-meter or CB antenna. The complete kit includes matching network, coaxial cable, and all required mounting hardware. The matching network includes a tuning indicator which dims at low swr. The kit is priced at \$27.40 postpaid. A complete report is available free, from Dept. HRR1, Microwave Filter Co., Inc., 6743 Kinne St., East Syracuse, New York 13057.

Stereo Phono-Input Interference Filter

A newly designed stereo interference filter has been introduced by Electronic Specialists. Radio-frequency energy from Amateur and CB transmissions often enters a stereo or hi-fi system through the phono or cassette input cables.

Designed to plug directly into the amplifier input jack, an Electronic Specialists filter in each amplifier input will greatly reduce or eliminate interference from this source. Their price is a low \$10.50 per pair. Write Electronic Specialists, Box 122, Natick, Massachusetts 01760.



Macrotronics Computer Products Catalog

Macrotronics is pleased to announce the availability of a complete line of hardware and software products for personal computers. Included are Amateur Radio interface systems for the TRS 80, PET, APPLE, and EXIDY Microcomputers.

A copy of the recently released catalog is available, free of charge, by writing to MACROTRONICS, P.O. BOX 747, Keyes, California 95328.

Modular Towers For Fixed-Station Or Portable Use

A new line of towers is offered by Lunar Electronics of San Diego, California. Modular design makes these towers a natural for site surveys, field operation, and portable communications of all types including Amateur Radio EME work.

The towers are made of aluminum angle pieces, which bolt together to form a sturdy structure that can support considerable antenna arrays. The basic tower package (model LT-1) consists

of a quadrilateral base, rotor and thrust-bearing mounting plates, and one modular tower section. The LT-1 yields a 3.4-meter-high (11-foot) structure when erected. Add-on modular sections (model LT-2) are 1.8 meter (6 feet) long. These add-on modular sections can increase tower height to nearly 9 meters (30 feet).

The tower can be readily mounted on flat or peaked roof tops. A length of 2x4 lumber placed under each leg pair provides a simple and effective mount. The 2x4s help to distribute tower weight over several roof joists. The modular tower sections must be guyed. Optional stainless-steel hardware is available (S suffix).

The tower is built from aluminum angle, so it forms its own ladder when properly erected and guyed. The base span is 109 cm square (43 inches square); tower sections are 24 cm square (9.5 inches square). Weight of base and lower tower section is about 25 kg (55 pounds). Each additional tower section weighs about 10 kg (22 pounds). Installation is an easy two-man job.

Further information is available from Lunar Electronics, 2785 Kurtz St., Suite 10, San Diego, California 92110, telephone: area code (714) 299-9470.

QSL Organizer

With today's more sophisticated rigs and less cluttered radio shacks, how do you keep QSL cards neatly organized, well preserved, dog-ear resistant, and always on beautiful display?

A specially designed Organizer is now available from Mil Industries of Panorama City, California. The QSL Organizer contains heavy duty plastic pages with roomy 10 x 15 cm (4 x 6 inch) slip-in pockets. Each page holds six QSLs (back to back) enhancing their appearance by its crystal clarity. The slip-in pockets allow cards to be arranged or re-arranged quickly and easily.

The QSL Organizer Album is specially designed to hold the

slip-in pocket pages. It's a beautiful three-ring binder, richly padded in long-lasting 'Brown-Hide' vinyl, with gold-printed inscription on cover and spine. Pages are easily inserted or removed.

The clear vinyl-pocketed pages are sold by Mil Industries at 47 cents each, with a 40 page minimum. The QSL Organizer Album is included free with every 40 pages ordered. Larger quantities

prices are available on request. The QSL Organizer comes with a full money-back guarantee.

QSL Organizers serve an important function in today's radio shack. They also make great gifts and great prizes for clubs and hamfests. They are available from Mil Industries, P.O. Box 44457, Panorama City, California 91402.

Mobile Antennas

A completely new line of mobile antennas has been introduced by Signals Communications Corporation. The new line covers 30 through 512 MHz. These high-performance, low-profile antennas feature plated whips, high-impact bases, and optional springs. These antennas will fill the needs of most professional and government applications. The Matchmate mobile-mount adapter system permits the mounting of Signals antennas on all popular mounts.

The mobile antennas feature solid dielectric coils enclosed in high-impact base covers. This configuration eliminates variation from coil to coil, thereby ensuring consistent high quality. The antennas are rated at 200 watts with less than 1.5:1 VSWR, and 50 ohms nominal impedance.

The antenna whips are long enough to permit cutting to frequency. They are made of quadrupled 17-7PH stainless steel. This results in lower skin effect losses and greater radiation.

Contact Signals Communications Corp., 1 Signals Park, P.O. Box 4833, Manchester, New Hampshire 03108.

KLAUS QUALITY AMATEUR RADIO EQUIPMENT & ACCESSORIES

KENWOOD

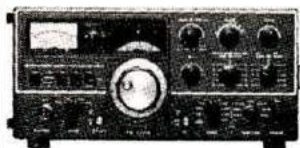

TS 520 S
HF TRANSCEIVER



TS 600
MULTIMODE 6-M
TRANSCEIVER



TS 820 S
HF TRANSCEIVER

... call or write for the **KLAUS** price ...

YAESU

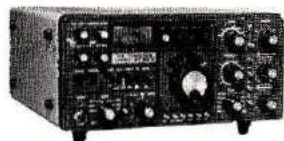

FT-901 D
HF TRANSCEIVER

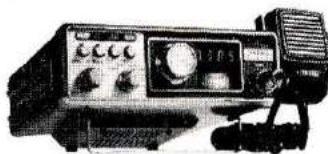

FT-227 R
2-METER FM TRANSCEIVER

... call or write for the **KLAUS** price ...

CUSHCRAFT

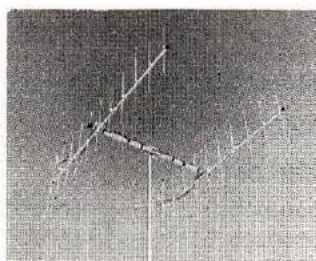
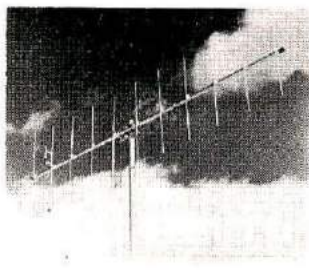

We have a complete stock of Cushcraft antennas — too many to mention in detail, so ask about our 2-meter line of verticals and beams for special low, low prices.

KLAUS RADIO Inc.

8400 N. Pioneer Parkway, Peoria, IL 61614

Phone 309-691-4840

Tim Daily, Amateur Equipment Sales Manager



"... must be Egypt!"



HORIZONS ad-scan

RATES Regular classified is available at 50¢ per word. Display classified (1 inch deep x 2 1/4 inches wide) is \$65, or at the 12x rate is \$50. All Ad Scan payable in advance. No cash discounts or agency commissions allowed.

HAMFESTS Sponsored by non-profit organizations receive one free regular classified ad (subject to our editing). Repeat insertions of hamfest ads pay the standard rate.

COPY No special layout or arrangements available. Material should be typewritten or clearly printed (not all capitals) and must include full name and address. We reserve the right to reject unsuitable copy. *HORIZONS* cannot check each advertiser and thus cannot be held responsible for claims made. Liability for correctness of material limited to corrected ad in next available issue.

DEADLINE 15th of third preceding month.

SEND MATERIAL TO: Ad Scan, Ham Radio Horizons, Greenville, N. H. 03048.

DISTINCTIVE QSL's — Largest selection, lowest prices, top quality photo and completely customized cards. Make your QSL's truly unique at the same cost as a standard card, and get a better return rate! Free samples, catalogue. Stamps appreciated. Stu, K2RPZ, Box 412, Rocky Point, NY 11778, (516) 744-6260.

HAM RADIO REPAIR, alignment. Hassle-free from anywhere via UPS. Expert, prompt, reasonable. Modern lab. "Grid" Gridley, W4GJO, Route 2, Box 138B, Rising Fawn, GA 30738

"HAMS FOR CHRIST" Reach other Hams with a Gospel Tract sure to please. Clyde Stanfield, WA6HEG, 1245 Sandra Ct., Upland, Calif. 91786.

NOVICES: Improve your skill with eight important operating aids on one 11" x 17" sheet; CW abbreviations, Q-signals, punctuation, U.T.C. conversion and more. \$2. postpaid. WD5KFN, Box 1296, Albany, TX 76430.

WANT TO START QRP (Low Power) Ham magazine. Anyone interested in subscriptions and/or contributing articles, write Lynn Woods, 1435 W. 25th, #6, Anchorage, Alaska 99503.

KENWOOD INTERNATIONAL USER'S CLUB is now operational. SASE for details. N8RT, Pohorence, 9600 Kickapoo Pass, Streetsboro, OH 44240.

ONLY MY FRIEND'S recent physical disability makes this top-grade equipment available; purchased new, still in as-new condition, complete with manuals/cables. Bill had literally a store full of items, \$10 to \$100 range; too costly to advertise the list, so tell me what you need. I want to move them now. Anyone having a difficult time learning code and operating CW? These like-new visual decoders and electronic typewriter keyboard: Pickering 230-D Morse Decoder, \$1500; Pickering KB-1 Electronic Keyboard keyer, \$140; Atronics CR-101 Code Reader, \$65; manuals/instructions. Collins: 51S1F, \$2050; 55G1, \$325; 30L1, \$995; 32S3A/516F2, \$1775; 312B4, \$425; all Round Emblem, immaculate w/manuals. Two Hy-Gain HT-18, 10-80 meter vertical antennas, \$195 each (phasing harness available); two Murch Ultimate Transmatch UT-2000A, \$125 each; DenTron 3000A antenna tuner, \$230; KLM Multi-2700 144 MHz transceiver, \$575; KLM PA 10-140 BL linear amplifier, \$175; Vista 120 v.a.c./13.8 v.d.c. power supply for above, \$136; excellent condition w/manuals. Ralph E. Thomas, W2UK, 9 Emmons Avenue, Farmingdale, NJ 07727; telephone (201) 938-5623.

ICOM 701 INTERNATIONAL USER'S CLUB. Details s.a.s.e. Pohorence, 9600 Kickapoo Pass, Streetsboro, Ohio 44240.

QSLs SECOND TO NONE. Same day service. Samples 50 cents. Include your call for free decal. Ray, K7HLR, Box 331, Clearfield, UT 84015.

CODE FLASH CARDS! Visualize code — don't try to pronounce it! Based on age-old principle for teaching math, language. Learn code easily, painlessly, in less time! Code Deck \$3.95. Gulf Press, 12 Bigelow Ctr., Ft. Myers Beach, FL 33931.

QSL ECONOMY: \$12 per 1000 UPS paid. S.A.S.E. for samples. W4TG, Drawer F, Gray, GA 31032.

MOBILE IGNITION SHIELDING provides more range with no noise. Bonding strap sale less than 50¢ each. Literature. Estes Engineering, 930 Marine Drive, Port Angeles, Wash. 98362.

QSLs with class! Unbeatable quality, reasonable price. Samples: 50¢ refundable. QSLs Unlimited, 1472 SW 13th Street, Boca Raton, FL 33432.

SOUNDS OF SHORTWAVE! 60-minute cassette by Bob Grove, WA4PYQ. Identify facsimile, jammers, telemetry, multiplex, teletype, many more! Side 2! Choosing a receiver, planning an antenna, coping with interference, more! \$5.95 postpaid. Grove Enterprises, Rt. 1, Box 156A, Brasstown, NC 28902.

QSLs & RUBBER STAMPS — Top Quality! QSLs: Glossy Inks and Cardstock. Rubber Stamps: Report forms, Call Letter, Address, State outlines — More! Stamp Catalog and Card Samples 50¢. Ebbert Graphics 5H, Box 70, Westerville, Ohio 43081.

DX — YOU BET! The DX Bulletin — Best weekly DX info in the world — send for FREE sample copy. The DX Bulletin, 306 Vernon Avenue, Vernon, Connecticut 06066.

WANTED: Operating instructions for HALLICRAFTERS SX-99. Glen Larsen, 34911 Buena Mesa Dr., Calimesa, CA 92320.

ELECTRONIC BARGAINS, CLOSEOUTS, SURPLUS! Parts, equipment, stereo, industrial, educational. Amazing values! Fascinating items unavailable in stores or catalogs anywhere. Unusual FREE catalog. ETCO-059, Box 762, Plattsburgh, N.Y. 12901.

"OHM SWEET OHM" placard, conversation piece. Suitable for framing. Postpaid \$1.00 WB9YMK, Stan Patla, Route #3, Box 254A. Lake Geneva, WI 53147.

QSL's, NAME TAGS, RUBBER STAMPS, Large catalog and samples 25¢. Budget Print Center, 130 Lincoln Highway West, New Haven, Indiana 46774.

STOP LOOKING for a good deal on amateur radio equipment — you've found it here — at your amateur radio headquarters in the heart of the Midwest. Now more than ever where you buy is as important as what you buy! We are factory-authorized dealers for Kenwood, Drake, Yaesu, Collins, Wilson, Ten-Tec, Atlas, ICOM, DenTron, MFJ, Tempo, Regency, Hy-Gain, Mosley, Alpha, Cushcraft, Swan and many more. Write or call us today for our low quote and try our personal and friendly Hoosier service. HOOSIER ELECTRONICS, P.O. Box 2001, Terre Haute, Indiana 47802. (812) 238-1456.

CODE got you stumped?

RELAX and worry not! Learn international Morse Code the EASY, Rus Farnsworth way. No books, no gimmicks, just listen & learn. Using the word method, based on modern psychological techniques, you can zoom past 13 w.p.m. in less than half the time! Available in cassettes @ \$10.95 and LP records at \$9.95 — you get over two hours of instruction!

EPSILON RECORDS
P.O. Box 626
San Jacinto, CA 92383

New Morse-A-Word Code Reader



The MORSE-A-WORD decodes audio signals from your receiver's speaker and displays characters visually as the code is received — great for short wave listeners. Built-in code practice oscillator — excellent for learning the code. MAWF \$249.95; Kit \$189.95. Check, money order, VISA, Master Charge. Add \$2.50 shipping for continental U.S. Wisconsin residents add 4% sales tax.

Microcraft

Corporation Telephone 614 241 8144
P. O. Box 513 HRH Thornville, Missouri 63092

AD SCAN

Your best buy
in Advertising!

CALL
800-258-5353

HRH LOCATOR

TO HELP YOU FIND YOUR LOCAL AMATEUR RADIO DEALER

Arizona

POWER COMMUNICATIONS
6012 N. 27 AVENUE
PHOENIX, AZ 85017
602-242-6030
Arizona's #1 "Ham" Store,
Kenwood, Yaesu, Drake, ICOM,
& more.

California

C & A ELECTRONIC ENTERPRISES
22010 S. WILMINGTON AVE.
SUITE 105
P. O. BOX 5232
CARSON, CA 90745
800-421-2258
213-834-5868 - Calif. Res.
Not the biggest, but the best —
since 1962.

JUN'S ELECTRONICS
11656 W. PICO BLVD.
LOS ANGELES, CA 90064
213-477-1824 Trades
714-463-1886 San Diego
The Home of the One Year Warranty
— Parts at Cost — Full Service.

SHAVER RADIO, INC.
1378 S. BASCOM AVE.
SAN JOSE, CA 95128
408-998-1103
Atlas, Kenwood, Yaesu, KDK, Icom,
Tempo, Wilson, Ten-Tec, VHF
Engineering.

TELE-COM
15460 UNION AVENUE
SAN JOSE, CA 95124
408-377-4479

Connecticut

THOMAS COMMUNICATIONS
95 KITTS LANE
NEWINGTON, CT 06111
800-243-7765
203-667-0811 - Conn. Res.
Call Us Toll Free —
See Our Full Page Ad in this Issue.

Delaware

DELAWARE AMATEUR SUPPLY
71 MEADOW ROAD
NEW CASTLE, DE 19720
302-328-7728
Icom, Ten-Tec, Swan, DenTron,
Wilson, Tempo, KDK, and more.
One mile off I-95, no sales tax.

Florida

AGL ELECTRONICS, INC.
1898 DREW STREET
CLEARWATER, FL 33515
813-461-HAMS
West Coast's Only Full Service
Amateur Radio Store

AMATEUR RADIO CENTER, INC.
2805 N.E. 2ND AVENUE
MIAMI, FL 33137
305-573-8383
The Place For Great Dependable
Names in Ham Radio

RAY'S AMATEUR RADIO
1590 US HWY. 19 SOUTH
CLEARWATER, FL 33516
813-535-1416
Atlas, B&W, Bird, Cushcraft,
DenTron, Drake, Hustler, Hy-Gain,
Icom, K.D.K., Kenwood, MFJ,
Rohn, Swan, Ten-Tec, Wilson.

SUNRISE AMATEUR RADIO
1351 STATE RD. 84
FT. LAUDERDALE, FL 33315
(305) 761-7676
"Best Prices in Country.
Try Us — We'll prove it."

Illinois

AUREUS ELECTRONICS INC.
1415 N. EAGLE STREET
NAPERVILLE, IL 60540
312-420-8629
"Amateur Excellence"

ERICKSON COMMUNICATIONS, INC.
5456 NORTH MILWAUKEE AVE.
CHICAGO, IL 60630
312-631-5181
Outside Illinois 800-621-5802
Hours 9:30-5:30 Mon., Tues., Wed.,
Fri.; 9:30-9:00 Thurs.; 9:00-3:00 Sat.

KLAUS RADIO, INC.
8400 NO. PIONEER PARKWAY
PEORIA, IL 61614
309-691-4840
Let Us Quote Your Amateur Needs.

SPECTRONICS, INC.
1009 GARFIELD STREET
OAK PARK, IL 60304
312-848-6777
One of America's Largest
Amateur and SWL Stores

Iowa

BOB SMITH ELECTRONICS
RFD #3, HIGHWAY 169 & 7
FORT DODGE, IA 50501
515-576-3886
For an EZ deal
800-247-2476/1793
Iowa: 800-362-2371

Kansas

ASSOCIATED RADIO COMM
8012 CONSER
OVERLAND PARK, KS 66204
913-381-5900
America's No. 1 Real Amateur Radio
Store. Trade - Sell - Buy.

Maryland

THE COMM CENTER INC.
9624 FT. MEADE ROAD
LAUREL PLAZA RT. 198
LAUREL, MD 20810
800-638-4486
R. L. Drake, Ten-Tec, Icom, Swan,
Tempo, Wilson, DenTron, Mosley.

Massachusetts

TEL-COM, INC.
675 GREAT RD., RT. 119
LITTLETON, MA 01460
617-486-3040
The Ham Store of New England
You Can Rely On.

Minnesota

PAL ELECTRONICS INC.
3452 FREMONT AVE. NO.
MINNEAPOLIS, MN 55412
612-521-4662
Midwest's Fastest Growing Ham
Store. Where Service Counts.

Nebraska

COMMUNICATIONS CENTER, INC.
443 N. 48 STREET
LINCOLN, NE 68504
800-228-4097
Kenwood, Yaesu, Drake and More
at Discount Prices.

New Hampshire

EVANS RADIO, INC.
BOX 893, RT. 3A BOW JUNCTION
CONCORD, NH 03301
603-224-9961
Icom, DenTron, Yaesu, Drake.
We service what we sell.

New Jersey

ATKINSON & SMITH, INC.
17 LEWIS STREET
EATONTOWN, NJ 07724
201-542-2447
Ham supplies since "55".

**BARGAIN BROTHERS
ELECTRONICS**
216 SCOTCH ROAD
GLEN ROC SHOPPING CTR.
WEST TRENTON, NJ 06828
609-883-2050
A million parts — Lowest prices
anywhere. Call us!

**BARGAIN BROTHERS II
ELECTRONICS**
181 HADDON AVENUE
WEST BERLIN, NJ 08091
609-767-5252
Surplus Parts and Equipment
Bought — Sold — Traded.

METUCHEN RADIO
216 MAIN STREET
METUCHEN, NJ 08840
201-494-8350
New and Used Ham Equipment.
WA2AET "T" Bruno

RADIOS UNLIMITED
P. O. BOX 347
1760 EASTON AVENUE
SOMERSET, NJ 08873
201-469-4599
New Jersey's Fastest
Growing Ham Store.

ROUTE ELECTRONICS 46
225 ROUTE 46 WEST
TOTOWA, NJ 07512
201-256-8555
Drake, Swan, DenTron, Cushcraft,
Hy-Gain, Hustler, Larsen and more.

WITTIE ELECTRONICS
384 LAKEVIEW AVE.
CLIFTON, NJ 07011
201-772-2222
Same location for 62 years.
Full-line authorized Drake dealer.

New York

**HAM-BONE RADIO
(Div. Stereo Repair Shop)**
3206 ERIE BOULEVARD EAST,
SYRACUSE, NY 13214
315-446-2266
We Deal, We Trade,
We Discount, We Please!
2-Way Service Shop on Premises!

HARRISON RADIO CORP.
20 SMITH STREET
FARMINGDALE, NY 11735
516-293-7990
"Ham Headquarters USA®"
since 1925.
Call toll free 800-645-9187.

RADIO WORLD
ONEIDA COUNTY AIRPORT
TERMINAL BLDG.
ORISKANY, NY 13424
800-448-7914
315-337-2622 } NY
315-337-0203 } Res.
New & Used Ham Equipment. See
Warren K2IXN or Bob WA2MSH

Ohio

**AMATEUR RADIO
SALES & SERVICE INC.**
2187 E. LIVINGSTON AVE.
COLUMBUS, OH 43209
614-236-1625
Antennas and Towers
for all services.

UNIVERSAL AMATEUR RADIO, INC.
1280 AIDA DRIVE
COLUMBUS (REYNOLDSBURG)
OH 43068
614-866-4267
Complete Amateur Radio Sales and
Service. All major brands - spacious
store - near I-270.

Pennsylvania

ELECTRONIC EXCHANGE
136 N. MAIN STREET
SOUDERTON, PA 18964
215-723-1200
Demonstrations, Sales, Service.
New/Used Amateur Radio Equip.

**HAMTRONICS, DIV. OF
TREVISE ELECT.**
4033 BROWNSVILLE RD.
TREVISE, PA 19047
215-357-1400
Same Location for
More Than 30 Years.

LaRUE ELECTRONICS
1112 GRANDVIEW STREET
SCRANTON, PENNSYLVANIA 18509
717-343-2124
ICOM, Bird, Cushcraft, CDE,
Ham-Keys, VHF Engineering,
Antenna Specialists.

South Dakota

**BURGHARDT
AMATEUR CENTER, INC.**
P. O. BOX 73
WATERTOWN, SD 57201
605-886-7314
"America's Most Reliable
Amateur Radio Dealer".

Texas

HARDIN ELECTRONICS
5635 EAST ROSEDALE
FORT WORTH, TX 76112
817-461-9761
You Bet Fort Worth
Has A Ham Store!

CALL TOLL FREE

For the best deal on

●AEA ●Ameco ●Apple ●ASP
●Belden ●Bencher ●Bird
●CDE ●CES ●Cushcraft
●Daiwa ●DenTron ●Drake
●Hy-Gain ●Icom ●KLM
●Kenwood ●Larsen ●MFJ
●Midland ●Mosley ●NPC
●Newtronics ●Nye ●Palomar
●Regency ●Shure ●Swan
●Standard ●Tempo ●Ten-Tec
●Tonna ●Transcom ●Wilson
●Yaesu

NEW for 1980! Apple Computers..

get Erickson's price!

RTTY interface available

Larsen Mag Mounts...

CLOSEOUT! 20 % off on
any Larsen mag mount
antenna in stock!

SUPER SPECIAL...

A few sets of Kenwood

Twins...while they last, \$799!



CALL TOLL FREE
(outside Illinois only)

(800) 621-5802



Hours:

9:30-5:30 Mon., Tues., Wed. & Fri.

9:30-9:00 Thursday

9:00-3:00 Saturday



ERICKSON

COMMUNICATIONS, INC.

5456 N. MILWAUKEE AVE

CHICAGO, IL 60630 (312) 631-5181

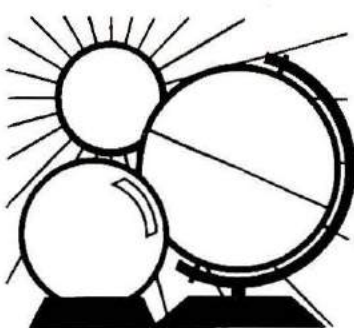

DX FORECASTER

You can expect a minor disturbance around February 4th and 5th, a more severe disturbance between the 15th and 20th with the likelihood of the earlier part of that period being very upset — both ionospherically and atmospherically — and, finally, another minor disturbance between the 23rd and 25th.

February, while still a winter month, represents a time of transition between winter and springtime conditions for propagation. Days will be getting noticeably longer in the northern hemisphere, and the frequencies above 20 MHz will be open longer. Bands below 20 MHz will be open to various parts of the world during hours of darkness and, except for occasional absorption of signals due to E-layer effects, even 160 meters will be superb!

In general, you can expect 10, 15, and 20-meter bands to open earlier in the morning and stay open later in the evening than during the winter, while the reverse will be true of the 40, 80, and 160-meter bands.

For EME people, lunar perigee occurs on February 17th. There will be a solar eclipse on February 16th in which totality will be observed in Africa, except for northernmost portions; southern Asia; Indonesia; and the Phillipines, except for the easternmost islands. The remainder of earth will see varying degrees of shadow as the moon covers portions of the solar disc.

Band-by-band summary

Six Meters will open occasionally for F2 propagation toward Europe and the east before noon, toward the south during the noon and early afternoon, and toward the west and north-

west in the late afternoon and early evening. Best openings are likely to be across the equator during afternoon hours.

Ten and Fifteen Meters will exhibit much the same kind of activity as six, except for more of it, with excellent worldwide DX on many days from shortly after sunrise until well after sunset. Directional characteristics will be similar to those expected for six meters. Also, excellent daytime short-skip openings will occur on most days.

Twenty Meters will be open nearly every day and night to some area of the world, except for very disturbed days. Expect the band to open around sunrise, and continue to bring DX signals until well after sunset. Peak conditions will occur just after sunrise and just before sunset for several hours each day. Short skip will abound. If you can't work 'em on twenty, you can't work 'em!

Forty and Eighty Meters will be very active to most areas of the world during the hours of darkness and just before sunrise. In late afternoon and early evening, the bands will open to Europe and the east, gradually swing around toward the south around midnight, and bring in signals from Pacific areas between midnight and dawn. Daytime short skip conditions will be excellent on most days.

One-sixty Meters will provide much DX during the hours of darkness and into the sunrise period on many days. Signals will be noted for their clarity against a quiet background. Transmit on a vertical and listen on a beverage antenna, if possible.

HRH

GMT	WESTERN USA										MID USA										EASTERN USA									
	ASIA FAR EAST	EUROPE	S. AFRICA	S. AMERICA	ANTARCTICA	OCEANIA NEW ZEALAND	AUSTRALIA	JAPAN	ASIA FAR EAST	EUROPE	S. AFRICA	S. AMERICA	ANTARCTICA	OCEANIA NEW ZEALAND	AUSTRALIA	JAPAN	ASIA FAR EAST	EUROPE	S. AFRICA	S. AMERICA	CARIBBEAN S. AMERICA	ANTARCTICA	OCEANIA NEW ZEALAND	AUSTRALIA	JAPAN					
PST	N	NE	E	SE	S	SW	W	NW	MST	N	NE	E	SE	S	SW	W	NW	CST	N	NE	E	SE	S	SW	W	NW	EST			
0000	10	—	20	10	15	10	10	10	5:00	—	40	15	15	—	10	15	15*	8:00	15	15	20	15	20	15	15	10	7:00			
0100	10	—	20	15	15	10	10	10	6:00	10	40	20	15	15	15	15	15*	7:00	20	20	20	15	20	15	15	15	8:00			
0200	15	—	20	15	20*	10	10	15*	7:00	15	40*	20	15	15	15	15*	8:00	15	40*	20	20	20	15	15	15	15	9:00			
0300	15	—	20	20	20*	10	10	15*	8:00	—	40*	20	20	15	15	15	15	9:00	20	40	20	20	20	20	20	20	10:00			
0400	20	—	20	20	20	15	15	20	9:00	—	40*	20	20	20	20	—	20	10:00	—	40	20	20	20	20	—	20	11:00			
0500	—	40	—	20	20	15	15	20	10:00	—	40*	—	20	20	20	—	20	11:00	—	40	20	20	20	20	—	20	12:00			
0600	—	40	—	20	20	20	—	—	11:00	—	40	—	20	20	20	—	20	12:00	—	40	20	20	20	20	—	—	1:00			
0700	—	40	—	20	20	20	—	—	12:00	—	40	—	40	20	20	—	—	1:00	—	40	20	20	20	20	—	—	2:00			
0800	—	40	—	20	20	20	—	—	1:00	—	40	—	40	20	20	—	—	2:00	—	40	—	20	20	20	—	—	3:00			
0900	—	20	—	40	20	20	—	40	2:00	—	40	—	40	20	20	—	—	3:00	—	40	—	40	20	20	—	—	4:00			
1000	—	20	—	40	20	40*	40*40	40	3:00	—	—	—	40	20	20	—	—	4:00	—	—	—	40	20	40	40	—	5:00			
1100	—	20	—	40	40	40	40*40	40	4:00	—	—	—	40	20	20	—	—	5:00	—	—	—	40	20	40	40	—	6:00			
1200	—	—	—	40	20	40	40	40	5:00	—	—	—	40	20	20	—	—	6:00	—	—	—	40*	—	—	—	—	7:00			
1300	—	—	—	—	—	40	40	40	6:00	—	20	—	40*	—	20	—	—	7:00	—	15	—	20	—	—	—	—	8:00			
1400	—	20	—	20	—	40*	20	40	7:00	—	—	—	20	—	20	20	—	8:00	—	—	—	20	20	20	—	—	9:00			
1500	—	20	—	20	20	20	20	40	8:00	20	10	—	10	—	20	20	20	9:00	10	10	10	10	10	10	—	—	10:00			
1600	20	10	—	10	—	15	20	40	9:00	20	10	10	10	—	15	20*	—	10:00	10	10	10	10	10	15	15	—	11:00			
1700	20	10	—	10	—	15	15	20	10:00	20	10	10	10	—	15	20*	—	11:00	20	10	10	10	10	15	15	—	12:00			
1800	15	10	10	10	—	15	15	20	11:00	20	10	10	10	—	15	20*	—	12:00	—	10	10	10	10	15	15	—	1:00			
1900	20	15	10	10	—	15	15	—	12:00	20	15	10	10	—	15	15	—	1:00	—	15	10	10	10	10	—	—	2:00			
2000	20	20	10	10	—	10	15	—	1:00	20	15	10	10	—	10	15	—	2:00	—	15	15	10	10	10	20	—	3:00			
2100	15	20	15	10	—	10	10	—	2:00	—	15	15	10	—	10	15	—	3:00	—	15	15	10	10	15	15	—	4:00			
2200	15	20	15	10	—	10	10	20	3:00	—	—	15	10	—	10	15	—	4:00	—	15	15	10	10	10	10	—	5:00			
2300	10	—	20	10	—	10	10	10	4:00	—	—	15	15	—	10	15	15	5:00	15	15	20	10	15	10	10	10	6:00			

HAM CALENDAR

February 1980

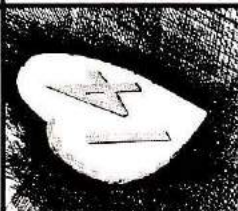
SUNDAY	MONDAY	TUESDAY	WEDNESDAY	THURSDAY	FRIDAY	SATURDAY
					ARRL News Roundup — 1:10	So. Carolina QSO Party — 1800Z-2100 — 2400Z 3rd New Hampshire QSO Party — 2400Z 2nd — 0300Z 3rd — 1400Z 3rd — 2200 4th Grounding Day: Expect calls to Coastal People JCI by Bristol (TN) ABC, TAM in Washington 2nd — W8DQJ — 2
	FLORIDA HAM NEWS — SWAP NET BY THE BROWARD ARC 146.31-31.7 at 7:30PM GLENHURST RADIO SOCIETY Transmits Amateur Radio News — 222.66/224.26 MHz via WR2APC and 21.400 MHz USB	AMSAT Eastcoast Net 3850 kHz 9PM EDT (0100Z) Wednesday Morning AMSAT Mid Continent Net 3850 kHz 9PM CDT (0200Z) Wednesday Morning AMSAT Westcoast Net 3850 kHz 8PM PST (0300Z) Wednesday Morning			1	2
3	FLORIDA HAM NEWS — SWAP NET BY THE BROWARD ARC 146.31-31.7 at 7:30PM GLENHURST RADIO SOCIETY Transmits Amateur Radio News WR2APC and 21.400 MHz USB WEST COAST BULLETIN EDITOR & Transmitted by WB2F BPM PST — 3540 kHz 4:1-7:30 WSP	AMSAT Eastcoast Net 3850 kHz 9PM EDT (0100Z) Wednesday Morning AMSAT Mid Continent Net 3850 kHz 9PM CDT (0200Z) Wednesday Morning AMSAT Westcoast Net 3850 kHz 8PM PST (0300Z) Wednesday Morning	6	7	8	9
10	FLORIDA HAM NEWS — SWAP NET BY THE BROWARD ARC 146.31-31.7 at 7:30PM GLENHURST RADIO SOCIETY Transmits Amateur Radio News WR2APC and 21.400 MHz USB WEST COAST BULLETIN EDITOR & Transmitted by WB2F BPM PST — 3540 kHz 4:1-7:30 WSP	AMSAT Eastcoast Net 3850 kHz 9PM EDT (0100Z) Wednesday Morning AMSAT Mid Continent Net 3850 kHz 9PM CDT (0200Z) Wednesday Morning AMSAT Westcoast Net 3850 kHz 8PM PST (0300Z) Wednesday Morning	13		15	16
	FLORIDA HAM NEWS — SWAP NET BY THE BROWARD ARC 146.31-31.7 at 7:30PM GLENHURST RADIO SOCIETY Transmits Amateur Radio News WR2APC and 21.400 MHz USB	AMSAT Eastcoast Net 3850 kHz 9PM EDT (0100Z) Wednesday Morning AMSAT Mid Continent Net 3850 kHz 9PM CDT (0200Z) Wednesday Morning AMSAT Westcoast Net 3850 kHz 8PM PST (0300Z) Wednesday Morning				Glasgow (KY) Swapnet: Glasgow, Feb Market Blog Highway 31E — 844-3PM — W442D — 23
17	FLORIDA HAM NEWS — SWAP NET BY THE BROWARD ARC 146.31-31.7 at 7:30PM GLENHURST RADIO SOCIETY Transmits Amateur Radio News WR2APC and 21.400 MHz USB	AMSAT Eastcoast Net 3850 kHz 9PM EDT (0100Z) Wednesday Morning AMSAT Mid Continent Net 3850 kHz 9PM CDT (0200Z) Wednesday Morning AMSAT Westcoast Net 3850 kHz 8PM PST (0300Z) Wednesday Morning	20	21	22	23
24	Lancaster (PA) Hamfest - Quernsey Pavilion Rt. 30, East — 24 Agonium ARC Feb Market, Marlboro (MA) Jr. High School — W1BK — 24 Vienna Wireless Society Winterfest — Vienna (VA) Community Center 8AM - 4PM — 24 Cuyahoga Falls (OH) Lunches & Feb Market — Varns High School, Akron 8AM - 4PM — 24 Lafayette (IN) Winter Hamfest — Davis Auditorium — 8AM — M4364 — 24 Bramatch ARC Hamfest — National Guards Academy, Elm, NC — 8AM - 3PM — N4AK7 — 24	AMSAT Eastcoast Net 3850 kHz 9PM EDT (0100Z) Wednesday Morning AMSAT Mid Continent Net 3850 kHz 9PM CDT (0200Z) Wednesday Morning AMSAT Westcoast Net 3850 kHz 8PM PST (0300Z) Wednesday Morning	27	28	29	

WHY WISH YOU'D BOUGHT ALPHA?



IS SOMETHING ELSE "JUST AS GOOD?"

New **ALPHA** owners often tell us, "I wish I'd saved my time and money and bought an **ALPHA** in the first place." Why not benefit from their experience? Compare first!

TRY TO GET ANY OTHER MANUFACTURER TO TELL YOU - IN WRITING - THAT IT'S SAFE TO OPERATE HIS DESK TOP LINEAR AT A FULL D-C KILOWATT ... SAY FOR 24 HOURS KEY-DOWN. OR, ASK HIM FOR A FULL YEAR WRITTEN WARRANTY. GOOD LUCK!

YOUR NEW ALPHA WILL HAPPILY AND COOLY RUN THAT KILOWATT KEY-DOWN ... FOR 24 DAYS IF YOU WISH. AND YOU'LL BE PROTECTED BY ETO'S UNMATCHED WARRANTY FOR TWO YEARS. WE PUT IT IN WRITING ALL THE TIME. IT'S THE WAY WE BUILD AND WARRANT EVERY ALPHA!

The new **ALPHA**s are the best we've ever built. Nothing else even approaches an **ALPHA**'s combination of power, convenience, quality, and owner protection. The ETO/**ALPHA** two year limited warranty offers you eight times as much protection as the industry standard 90 day warranty.

The new **ALPHA 78** combines major capabilities that you can't get in any other linear amplifier plus all the traditional **ALPHA** qualities. You can hop instantly from one HF band to another with **NO TUNE UP** ... with truly conservative maximum legal power in all modes including SSTV and RTTY ... and with **NO TIME LIMIT** on key-down time at full power!

You can work full CW break-in with the **ALPHA 78** (provided your exciter/transceiver's up to it!), using the same vacuum relay high speed QSK system made famous by the "Ultimate Linear" **ALPHA 77Dx**. And if new amateur bands are granted, you can manually tune your **ALPHA** to work them, too.

The standard of high power convenience established back in 1974 by the original **ALPHA 374** has gone unchallenged ever since. In 1980, **ALPHA 374A** and **ALPHA 78** are still the only linears that offer you *both* maximum legal power *and* no-tune-up convenience. Not to mention sleek "one cubic foot" desk-top packaging. And these newest **ALPHA**'s are even huskier than their famed predecessors: bigger transformers, quieter and more efficient cooling systems, more robust RF components. **ALPHA**'s exclusive two year limited warranty is no accident - it tells you a lot about how an **ALPHA**'s built.

Before you get serious about any other brand of linear, compare its convenience and quality, its transformer heft, its cooling system efficiency and noise level and its warranty - with the **ALPHA**'s. Be sure to ask around about its reputation.

Call or write for detailed literature and thoroughly check out all the great new **ALPHA**'s ... so you don't make a mistake.



EHRHORN TECHNOLOGICAL OPERATIONS, INC.
BOX 708, CAÑON CITY, CO. 81212 (303) 275-1613

AD CHECK

... for literature, in a hurry — we'll rush your name to the companies whose names you check.

Place your check mark in the space between name and number. Example: HRH 150.

AR Tech. ___ 687	Larsen ___ 078
Aluma ___ 589	Long's ___ 468
Anteck ___ 733	Lunar ___ 577
Avanti ___ 775	MFJ ___ 082
Bencher ___ 629	MIL ___ 795
Comm. Center ___ 534	Macrotronics ___ 820
Con-puter I ___ 804	Madison ___ 431
Cover Craft ___ 685	Maggiore Elec. Lab. ___ 821
Cornell-Dubilier ___ 241	Microcraft ___ 774
Curtis Electro ___ 034	Microwave Filter ___ 637
DSI ___ 656	Oak Hill Academy A.R.S. *
Drake *	Palomar Eng. *
E.T.O. *	RCA Distr. ___ 782
Electronic Specialists ___ 372	RF Power Comp. ___ 542
Erickson *	RSE Ham Shack ___ 607
Gilfer ___ 207	Callbook ___ 100
Hal *	Constructor *
Ham Gear Mart *	S-F A. R. S. ___ 640
HRB ___ 150	SST ___ 375
HORIZONS *	Sem Con ___ 808
Hustler ___ 171	Signals Com. ___ 822
Hy-Gain ___ 064	Snow Micro Sys. ___ 816
Icom *	Swan ___ 111
KLM ___ 073	Tedco ___ 791
Kantronics *	Ten-Tec *
Kenwood *	Tri-Ex ___ 116
Klaus ___ 430	Van Gorden ___ 737
Lafayette Radio ___ 819	Wilson Sys. ___ 787

*Please contact this advertiser directly.

Limit 15 inquiries per request.

FEBRUARY 1980

Please use before March 31, 1980

Tear off and mail to
HAM RADIO HORIZONS — "Ad Check"
Greenville, N. H. 03048

NAME _____

CALL _____

STREET _____

CITY _____

STATE _____ ZIP _____

VALENTINE VALUES

Cushcraft "boomer"	\$ 69.95
OMNI-J 2 Meter Antenna	39.95
Tonna F9FT Antennas 144/16 el.	59.95
Klitzing VHF-UHF Amplifiers	
2M 10W in - 100W Out	179.95
432 10W in - 50W Out	189.95
Bird 43 and slugs, UPS paid in USA ...	stock
Microwave Modules, less 15% off list	stock
Telrex TB5EM, in stock	415.00
New Telrex TB5ES, 2 KW pep version	315.00
New Palomar Engr. Trans. Preamp	89.50
Bencher Paddles — \$39.95 Chrome	49.95
Vibroplex paddles in stock, plus bugs,	
write for prices.	
ETO 76 Amplifiers	stock
Lunar 6M-2M-220 In Line Preamps	49.95
Janel QSA-5	41.95
HAM-X Tailwister Rotor	189.95
HAM-4 Rotor	139.95
Cetron 572B	29.50
New HDI HC-1400 144/148MHZ, 25 watt,	
Synthesized 2 meter transceiver	349.00
Remote digital readout	49.95
Motorola HEP170	0.29
Mallory 2.5A/1000PIV epoxy diode	0.19
Aerovox 1000PF/500V Feed thru cap	1.95
Technical Books: Ameco, ARRL, Sams, Tab,	
Rider, Radio Pub., Callbook, Cowan,	
WRTVH, etc.	Call
NEW Belden 9405 (2#16)(6#18) 8 wire rotor	
cable, heavy duty for long runs	0.32/ft
8448 8 wire rotor cable	0.20/ft
9888 double shield RG8 Foam	0.46/ft
8214 RG8 Foam	0.26/ft
8237 RG8 Regular	0.23/ft
8267 RG213	0.30
Amphenol Silver Plate PL259 (831SP)	0.69
Belden 14 ga. stranded antenna wire	
#8000	0.06/ft
Times 1/2" Foam Hardline \$0.65/ft. —	
Connectors, ea.	15.00
Berktek RG8X, 52 ohm, KW, per ft.	0.16
Robot "Slow Scan" Now in Stock	Call
Alliance HD73 Rotor	109.95
Teletow r-self support-	
55 ft/w breakover	549.00
40 ft/w breakover	399.00
Telrex antennas? In Stock! Monobanders?	
You bet!	

Looking for antique parts?
Write specific need to W5GJ.

THIS MONTH'S SPECIALS:

Icom IC701, AC, MIC — \$1,195.00
NEW ICOM IC255A, 2M — \$349.00

Dentron GLA 1000 Amp. \$319.00

Dentron Clipperton L — \$499.00

(Limited Qty.)

New Price \$599.00 after current
supply runs out.

Kenwood TS700SP \$599.00;

TR7625 \$399.00;

TR7600 \$299.00; RM76 \$99.95.

Limited Qtys.

MASTERCHARGE • VISA

All prices fob Houston except where indicated. Prices subject to change without notice, all items guaranteed. Some items subject prior sale. Send letterhead for Dealer price list. Texas residents add 6% tax. Please add postage estimate \$1.00 minimum.

MADISON
ELECTRONICS SUPPLY, INC.
1508 MCKINNEY
HOUSTON, TEXAS 77002
713/658-0268

AD INDEX

AR Technical Products, Inc.	47
Aluma Tower Co.	30
Bencher, Inc.	30, 79
Communications Center	23
Cover Craft	79
DSI Instruments	35
Drake Co., R. L.	10
Ehrhorn Technological Operations	77
Erickson Communications	74
Hal Communications Corp.	9
Ham Gear Mart	42
Ham Radio's Bookstore	30, 37, 42, 47, 66, 71, 79
Ham Radio HORIZONS	47, 80
Icom	7
KLM Electronics, Inc.	Cover IV
Kantronics	29
Trio-Kenwood Communications, Inc.	Cover III
Klaus Radio, Inc.	70
Long's Electronics	40, 41,
MFJ Enterprises	3
Madison Electronic Supply	30, 47, 78
Microcraft Corporation	71
Microwave Filter, Inc.	79
Oak Hill Academy Amateur Radio Session	47
Palomar Engineers	37
RF Power Components	42
RSE Ham Shack	51
Radio Amateur Callbook	58
Radio & Electronics Constructor	42
S-F Amateur Radio Services	42
Swan Electronics	1
TEDCO	47
Ten-Tec	Cover II
Tri-Ex Tower Corp.	62
Van Gorden Engineering	79
Wilson Systems, Inc.	4, 52, 53

Foreign Subscription Agents for Ham Radio HORIZONS

Ham Radio Austria
F. Bastl
Hauptplatz 5
A-2700 Wiener Neustadt
Austria

Ham Radio Holland
MRL Electronics
Postbus 88
NL-2204 Delt
Holland

Ham Radio Belgium
Sternohouse
Brusselsesteenweg 416
B-9218 Gent
Belgium

Ham Radio Italy
G. Vulpelti
P.O. Box 37
I-22063 Cantu
Italy

Ham Radio Canada
Box 400, Goderich
Ontario, Canada N7A 4C7

Ham Radio Switzerland
Karin Lieber
Postfach 2454
D-7850 Loerrach
West Germany

Ham Radio Europe
Box 444
S-194 04 Upplands Vasby
Sweden

Ham Radio France
SM Electronic
20 bis, Ave des Clarions
F-89000 Auxerre
France

Ham Radio UK
P.O. Box 63, Harrow
Middlesex HA3 8HS
England

Ham Radio Germany
Karin Lieber
Postfach 2454
D-7850 Loerrach
West Germany

Holland Radio
143 Greenwood
Greenside, Johannesburg
Republic of South Africa



the Ultimate IAMBIC PADDLE

WRITE FOR LITERATURE

BENCHER, INC.

333 W. Lake Street, Dept. A
Chicago, Illinois 60606 • (312) 263-1808

- Full range of adjustment in tension and contact spacing.
- Self-adjusting nylon and steel needle bearings.
- Solid silver contact points.
- Polished lucite paddles.
- Precision-machined, chrome plated brass frames.
- Standard model has black, textured finish base; deluxe model is chrome plated.
- Heavy steel base; non-skid feet.

Available at selected dealers or send \$39.95 (\$49.95 for chrome model) plus \$2.00 shipping and handling. Overseas amateurs invited to request quotation for air parcel post shipment.

UNADILLA

FULL-POWER, QUALITY HAM ANTENNA PARTS

AT YOUR DEALER



The WA2ZOT "INTERFILTER"

2000 WATT LO-PASS

LIFETIME GUARANTEE

The only Lo-Pass you'll ever need.

- BALUNS-TRAPS-INSULATORS
- QUAD PARTS-ANTENNA KITS
- BOOM/MAST MOUNTS-WIRE
- CABLE-CONNECTORS

Write or call for full Catalog

ASSISTANCE?
Call: HUGH GUNNISON, WA2ZOT
Toll-Free 800-448-1666
(NYS Collect 315-437-3953)

MICROWAVE UNADILLA/REYCO DIVISION
FC FILTER COMPANY, INC. [Dept. HRH]
8743 KINNE STREET, EAST SYRACUSE, NEW YORK 13057

DEALERS WANTED - OVER 300 WORLD-WIDE

HI-Q BALUN

- For dipoles, yagis, inverted vees & doublets
- Replaces center insulator
- Puts power in antenna
- Broadbanded 3-40 MHz
- Small, lightweight and weatherproof
- 1:1 Impedance ratio
- For full legal power and more
- Helps eliminate TVI
- With SO 239 connector

\$10.95



HI-Q ANTENNA CENTER INSULATOR

- Small, rugged, lightweight, weatherproof
- Replaces center insulator
- Handles full legal power and more

\$5.95 With SO 239 connector



HI-Q ANTENNA END INSULATORS

- Rugged, subminiature, injection molded of top quality material with high dielectric qualities and excellent weatherability. End insulators are constructed in a special mounting fashion to permit winding of loading coils or partial winding the hard traps.
- May be used for
 - Guy wire strain insulators
 - End or center insulators for antennas
- Construction of antenna loading coils or multiband traps

\$4.95



DIPOLES

MODEL	BANDS	LENGTH	PRICE WITH HI-Q BALUN	WITH HI-Q CENTER INSULATOR
Dipoles				
D-80	80-75	130	\$28.95	\$24.95
D-40	80-15	66	29.95	21.95
D-20	20	33	24.95	19.95
D-15	15	27	23.95	19.95
D-11	11	16	22.95	18.95
Shortened dipoles				
SD-80	80-75	90	31.95	27.95
SD-40	40	45	26.95	24.95
Parallel dipoles				
PD-8010	80-40-20-10-15	130	39.95	35.95
PD-4010	40-20-10-15	66	33.95	29.95
PD-8030	80-40-15	130	35.95	31.95
PD-4020	40-20-15	66	29.95	25.95
Dipole shorteners - only, same as included in SD models				
S-80	80-75		\$11.95 pr	
S-40	40		\$10.95 pr	

All antennas are compatible with HI-Q Balun or HI-Q Antenna Center Insulator. No. 14 antenna wire is recommended. This multi-antenna support system (SO) models only. SO insulators for full legal power. Antennas may be mounted as inverted Y, and may also be used by MARS or NARS.

Antenna accessories - available with antenna orders:
Nylon guy rope - 4500 5/8" dia. 100' long \$14.95
Ceramic Dielectric Tapered Antenna Insulators \$1.00 pr
SO 239 Coax Connector \$5.00

All prices are FOB and USA 48
Available at your favorite dealer or direct from us.

Van Gorden Engineering
BOX 21392, S. EUCLID, OHIO 44121 Dealer Inquiries Invited

In times like these . . .

Don't risk it.



- Dust Covers increase reliability. Increase resale value.
- Try our low-cost protection for ALL your equipment . . . before it's too late.
- only **\$4.95**
- Protects equipment and investment.
- Great looking.
- 100's of designs.
- Extra strength heavy gauge vinyl.
- Machine stitched.
- Satisfaction guaranteed.

See your dealer or contact:

COVER CRAFT

Box 555 • Amherst, NH 03031 • (603) 889-6811

FREE BOOK CATALOG

Whether you're interested in Amateur Radio, Electronics, Microprocessing, Microcomputer, Radio Astronomy, Old-Time Radio, VHF, SSB or just novels that involve Amateur Radio — you'll find a large selection of these books and more! Vast inventory of over 200 titles. Send your name and address to:

HAM RADIO'S BOOKSTORE

Greenville, NH 03048



The past year has seen a major change in the Amateur scene. For the first time in quite a while we are seeing a big drop in newcomers to the hobby. At the same time, however, the number of Technician, General and Advanced class Amateurs continues to grow at a rapid rate. Obviously the action is now in the middle ranks of Amateurs and that's just where Ham Radio HORIZONS is going to head, but without forgetting the beginner!

Some really big plans are afoot and I'll bet you're going to like them. You may already have seen the first of our new equipment user reports in the December issue. It's a report where actual owners and users, not some editor or lab technician, evaluate popular pieces of Amateur gear. This is a real no-holds-barred type of reporting and you'll get it only in Ham Radio HORIZONS.

Starting in our March issue Bill Orr, W6SAI, will join us as a regular monthly columnist. One of Amateur Radio's most popular writers, Bill will be covering his specialty, antennas. In addition, he'll have fact-filled articles on equipment design, new products, projects, and more. You'll be finding Bill only in Ham Radio HORIZONS! And there's more.

A regular DX column that will feature not just who's working whom, but solid factual information that will be of great use to both the serious and the casual DX'er. The mystery of propagation will be uncovered by noted forecaster W1XU in the March issue. Jim tells all about the best bands to use, an explanation of MUF, how the sun influences the atmosphere and more. You get the tools you need to build your knowledge of the radio propagation phenomenon. Future issues will cover just about every angle in the fascinating pursuit of rare DX. And there's much, much more!

Another exciting and very useful new feature will be a Q & A column written by Tom McMullen, W1SL. Tom has spent many years in both the broadcasting and Amateur Radio field. His answers to the questions you send in will help you get the most out of your station and Amateur Radio operation.

All of this will be put together in a magazine with an exciting new look — a new cover design — a new more interesting and readable page layout. You'll know it's the great new HORIZONS the moment you lay eyes on it. It's Amateur Radio's most exciting magazine.

So there it is. We hope you are as excited about the March issue as we are! One more thing, if you bought this issue on the newsstand — how about trying a subscription. Just fill out and mail the handy bind-in card found between pages 68 and 69. Join those who know HORIZONS is the magazine for the 80's.

**HAM RADIO
HORIZONS**

YOUR BEST BET FOR THE 80s

R-1000 Brings You The World.



Now, a high-performance, easy-to-operate Communications Receiver with single-knob tuning system and digital frequency display!

Up-to-the-minute events and information from anywhere in the world, including foreign shortwave broadcast (music, news, propaganda, etc.), emergency ship communications and other marine traffic, standard AM broadcast, Amateur Radio Operators, all 40 CB channels, military and government messages, long-distance industrial communications, standard time/frequency signals...and other exciting transmissions...it's all yours through the R-1000!

Highly accurate, sensitive, selective, and stable, the R-1000 has a unique fast-tuning system that covers the shortwave bands, plus medium-wave and long-wave frequencies. Even SSB communications signals are received perfectly.

Its many features include:

- Continuous frequency coverage from 200 kHz to 30 MHz
- 30 bands, each 1 MHz wide
- Accurate five-digit frequency display and illuminated analog dial

- Built-in quartz digital clock and ON/OFF timer
- Up-conversion PLL circuit and wideband RF circuits provide exceptional performance and easy operation without the need for bandspread, preselector, or antenna tuning
- Multi-modes... AM (wide and narrow), SSB (USB and LSB), and CW
- Three built-in IF filters... for SSB and CW (2.7 kHz), for AM narrow (6.0 kHz), and for AM wide (12 kHz)
- Effective communications-type noise blander (superior to noise limiter)
- Step attenuator (0-60 dB in 20-dB steps) to prevent overload
- Recording terminal (built-in timer controls recording time through remote terminal)
- Tone control for best audio response
- Built-in 4-inch speaker for quality sound reproduction
- Illuminated S-meter

- Dimmer switch to control panel lights and digital display intensity
- Adjustable bracket for optimum operating angle
- Three antenna terminals for high-impedance wire leads and a 50-Ω coaxial lead

Optional Accessories:

- SP-100 matching external speaker
- HS-4 and HS-5 headphones

The exciting R-1000 is designed specifically for those who demand the highest quality and it's available only through selected communications equipment specialists.

Write or call today for more information and for the address of your nearest Authorized Kenwood Communications Dealer.



KENWOOD

TRIO-KENWOOD COMMUNICATIONS INC.
1111 WEST WALNUT / COMPTON, CA 90220
TELEPHONE: (213) 639-9000

WHEN THE KT-34 SPEAKS ... THE WORLD LISTENS.

(JUST ASK JAY O'BRIEN, W6GO)



100 COUNTRIES IN 4½ MONTHS WITH KLM'S KT-34 TRIBANDER!

Congratulations, Jay, on earning the DXCC award (100 countries confirmed!)

Jay is one of those knowledgeable hams who recognized, right from the start, the KT-34's superior design and performance (maybe he was a little surprised by its strong DX capabilities). Look what the KT-34 delivers:

- ★ Phone and CW on 20, 15, and 10M with no retuning
- ★ Linear loading for reduced size, weight, and windload
- ★ 4 KW balun to eliminate matching hassles
- ★ Tough Lexan insulators and stainless steel electrical hardware
- ★ Now, booms of strong 6063-T832 aluminum alloy

And, equally important, the absence of power robbing coils puts the KT-34 in an ENERGY-EFFICIENT class all by itself ... your signal goes out, not up in smoke. Just ask Jay!

KLM's KT-34 VOICE OF AUTHORITY
ON 20, 15, and 10 METERS

KLM, 17025 Laurel Rd., Morgan Hill, CA 95037 (408) 779-7363



W6GO's SYSTEM

KLM KT-34 @ 56 ft.
(125' Belden 8214)
Drake TR-7
Dentron MLA2500B